

High-Speed, 1-Needle, Zigzag Lockstitch with an Automatic Thread Trimmer

LZ-2280

1. MACHINE FRAME & MISCELLANEOUS COMPONENTS (1)

頭部・外装関係 (1)

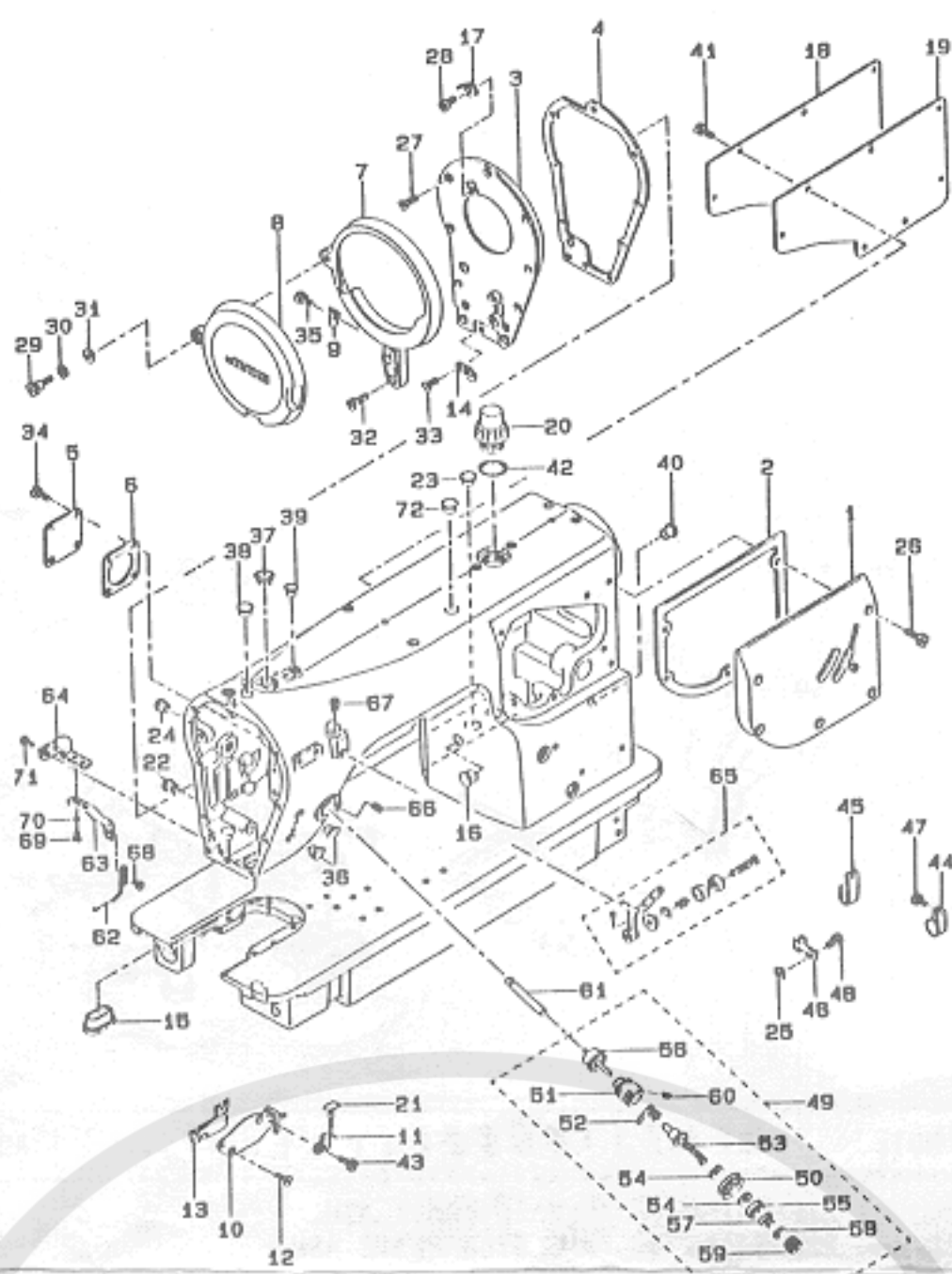

REF. NO	NOTE	PART NO.	DESCRIPTION	QTY.
1		225-01159	ARM SIDE COVER COMPL.	1
2		225-01209	GASKET	(1)
3		225-01357	FACE PLATE COMPL.	1
4		225-01506	GASKET	1
5		225-01805	TENSION RELEASE WINDOW PLATE	1
6		225-01704	GASKET	1
7		225-02009	BALANCE COVER BASE	1
8		225-02108	BALANCE COVER	1
9		225-02207	SPRING	1
10		225-02603	BALANCE THREAD GUIDE	1
11		225-02702	SPRING GUARD	1
12		225-02801	SCREW	2
13		225-02900	BALANCE THREAD GUIDE COVER	1
14		225-03007	BALANCE THREAD GUIDE B	1
15		100-00206	ARM OIL SHIELD	1
16		TA-1050604-RO	RUBBER PLUG	1
17		100-01709	TAKE-UP THREAD CUTTER	1
18		110-70901	SIDE PLATE	1
19		110-00819	GASKET	1
20		110-46804	OIL SIGHT WINDOW	1
21		110-43601	RUBBER STOPPER	1
22		TA-0800504-RO	PLUG D=8 L=4.5	1
23		TA-1050604-RO	RUBBER PLUG	2
24		TA-0750404-RO	PLUG D=7.5 L=3.5	1
25	#01	VT-0530002-KS	TOOTHED WASHER	1
26		SS-4121415-SP	SCREW 3/16-28 L=14	5
27		SS-1110840-SP	SCREW 11/64-40 L=8	9
28		SS-7080410-SP	SCREW 1/8-44 L= 3.8	1
29		SD-0640751-SP	HINGE SCREW D= 6.35 H= 7.5	1
30		VZ-0641510-KP	WAVED WASHER 6.4X11X0.3	1
31		WP-0651056-SD	WASHER 6.5X11X1	1
32		SS-4110915-SP	SCREW 11/64-40 L=9	2
33		SS-2090710-SP	SCREW 9/64-40 L=7	1
34		SS-4120815-SP	SCREW 3/16-28 L=8	4
35		SS-6120620-TP	SCREW	1
36		TA-0900707-RO	RUBBER PLUG	2
37		TA-1250705-RO	RUBBER PLUG	1
38		TA-1100604-RO	PLUG	1
39		TA-0750704-RO	RUBBER PLUG	1
40		TA-0750704-RO	RUBBER PLUG	1
41		SS-4121015-SP	SCREW 3/16-28 L=10	8
42		RO-1952401-00	RUBBER RING	1
43		SS-5090420-SP	SCREW 9/64-40 L=3.5	1
44	#01	EA-9502802-00	CABLE CLIP C	1
45	#01	D2112-555-B00	CORD HOLDER, LARGE	2
46	#01	110-30301	CABLE HOLDER	1
47	#01	SS-4121015-SP	SCREW 3/16-28 L=10	1
48	#01	SS-4121015-SP	SCREW 3/16-28 L=10	1
49		225-28053	THREAD TENSION ASM.	1
50		225-28350	THREAD TENSION DISK COMPL.	(1)
51		225-28152	THREAD TENSION ROD ASM.	(1)
52		100-06104	TAKE-UP SPRING	(1)
53		100-05650	TENSION POST ASM.	(1)
54		100-05916	FELT	(2)
55		100-06005	TENSION DISK HOLDER	(1)
56		100-07854	TENSION RELEASE PIN ASM.	(1)
57		B3129-012-A00	TENSION SPRING	(1)
58		B3120-125-000	ROTATING STOPPER	(1)
59		B3116-125-000	TENSION NUT	(1)
60		SS-8090670-SP	SCREW 9/64-40 L= 5.5	(1)
61		225-28608	THREAD RELEASE PIN SUPPORT	1
62		225-29002	SUPPORT BALANCE	1
63		225-29101	SUPPORT BALANCE BASE	1
64		225-29200	MOUNTING BASE	1
65		100-05353	PRE-TENSION CONTROLLER ASM.	1
66		SS-8110750-SP	SCREW 11/64-40 L= 6.5	1
67		SS-4110715-SP	SCREW 11/64-40 L=7	1
68		SS-6090540-SP	SCREW 9/64-40 L= 5.0	1
69		SS-6580612-TP	SCREW 1/8-40 L=6.3	2
70		VP-0330500-0E	WASHER 3.3X8X0.5	2
71		SS-4110915-SP	SCREW 11/64-40 L=9	2
72		TA-1250705-RO	RUBBER PLUG	1

Note (注記) #01...FOR LZ-2280-7, LZ-2286-7

2. MACHINE FRAME & MISCELLANEOUS COMPONENTS (2)

頭部・外装関係 (2)

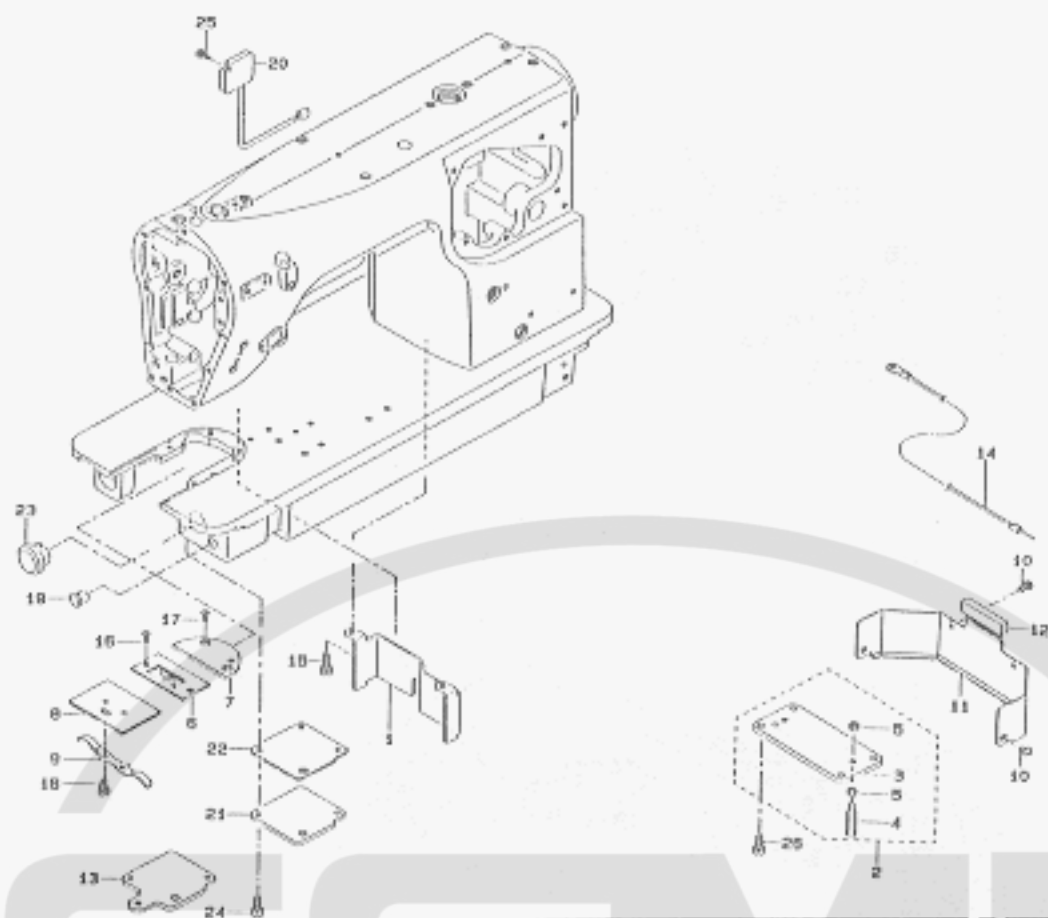

REF. NO	NOTE	PART NO.	DESCRIPTION	AMT.
1		225-01803	SUPPORT PLATE	1
2		225-01951	HELICAL GEAR BOX COVER ASH.	1
3		225-01902	HELICAL GEAR BOX COVER	(1)
4		101-00410	BED SCREW STUD	(2)
5		NS-6700320-SP	NUT 5/16-24	(4)
6		225-45008	FEEDER	1
7		100-04208	BED PLATE	1
8		100-04307	BED SLIDE	1
9		110-01609	BED SLIDE SPRING	1
10		SS-4110515-SP	SCREW 11/64-40 L=5	2
11		100-37307	OIL SHIELD PLATE	1
12		100-37406	OIL SHIELD RUBBER	1
13	#01	225-52400	HELICAL BEVEL GEAR BOX COVER	1
14	#01	110-44504	GROUND WIRE ASH.	1
15		SS-4111215-SP	SCREW 11/64-40 L=12	2
16		SS-2090820-TP	SCREW 9/64-40 L=8	2
17		SS-2090820-TP	SCREW 9/64-40 L=8	2
18		SS-6060210-SP	SCREW 3/32-56 L= 1.9	2
19		TA-0950806-RO	RUBBER PLUG	1
20	#02	M6094-350-AAL	PUMP BASE	1
21		100-31805	HELICAL BEVEL GEAR BOX COVER	1
22		100-31904	GASKET	1
23		100-32001	NYLON CAP	1
24		SS-4110915-SP	SCREW 11/64-40 L=9	3
25	#01	SS-4121015-SP	SCREW 3/16-28 L=10	1
26		SS-4110915-SP	SCREW 11/64-40 L=9	4

Note (注記) #01...FOR LZ-2280-7, LZ-2286-7
#02...FOR LZ-2280-7

3. HOOK DRIVING SHAFT & HOOK COMPONENTS

下軸・釜関係

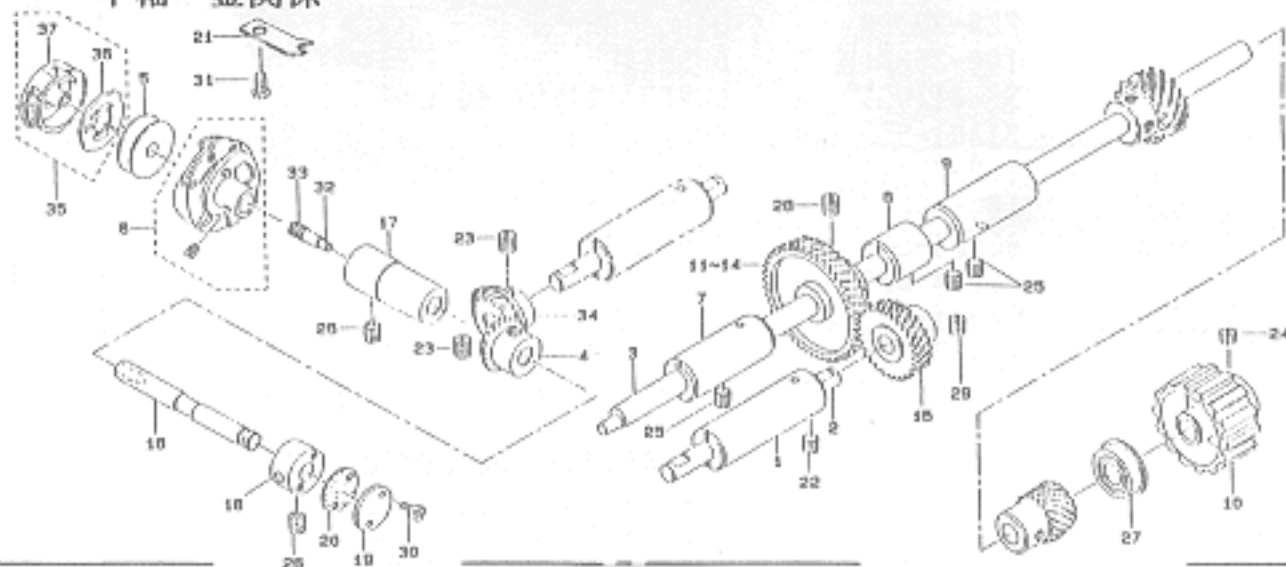

REF.NO	NOTE	PART NO.	DESCRIPTION	ANT.
1		225-23708	BUSHING	1
2		225-23807	SHAFT	1
3		225-23906	HOOK DRIVING SHAFT	1
4		B1308-155-0A0	PINION ASM.	1
5		225-24201	BOBBIN	1
6		225-24458	HOOK COMPL.	1
7		100-30104	BUSHING, FRONT	1
8		100-30203	BUSHING, INTERMEDIATE	1
9		100-30302	BUSHING, REAR	1
10		100-30401	HOOK DRIVING SHAFT SPROCKET	1
11	#01	100-30609	HELICAL GEAR A, A	1
12	#01	100-30708	HELICAL GEAR A, B	1
13	#01	100-30807	HELICAL GEAR A, C	1
14	#01	100-30906	HELICAL GEAR A, D	1
15		100-31003	HELICAL GEAR B	1
16		100-31359	HOOK SHAFT ASM.	1
17		100-31409	HOOK SHAFT BUSHING	1
18		100-31508	HOOK SHAFT BUSHING	1
19		100-31607	BUSHING CAP	1
20		100-31706	GASKET	1
21		100-33207	BOBBIN CASE POSITIONING FINGER	1
22		SS-8150710-SP	SCREW 15/64-28 L=7	1
23		SS-8660810-TP	SCREW 1/4-40 L=8	4
24		SS-6660710-TP	SCREW 1/4-40 L=7	2
25		SS-8150710-SP	SCREW 15/64-28 L=7	3
26		SS-8150710-SP	SCREW 15/64-28 L=7	2
27		SB-1095301-00	BEARING D=9.52X22.22	1
28		SS-8660810-TP	SCREW 1/4-40 L=8	2
29		SS-8660810-TP	SCREW 1/4-40 L=8	2
30		SS-4080620-TP	SCREW 1/8-44 L=6	2
31		SS-6111010-SP	SCREW 11/64-40 L= 9.5	1
32		B1808-552-000	OIL SEAL SCREW	1
33		B1810-552-000	OIL WICK	1
34		B1307-155-0A0	GEAR ASM. LARGE	1
35	#02	225-24169	BOBBIN CASE ASM.	1
36		137-29702	BOBBIN CASE SPRING	(1)
37		225-24151	BOBBIN CASE COMPL.	(1)

Note (注記) #01...SELECTIVE PART

#02...FOR LZ-2280-7, LZ-2286-7

4. MAIN SHAFT • NEEDLE BAR COMPONENTS

上軸・針棒関係

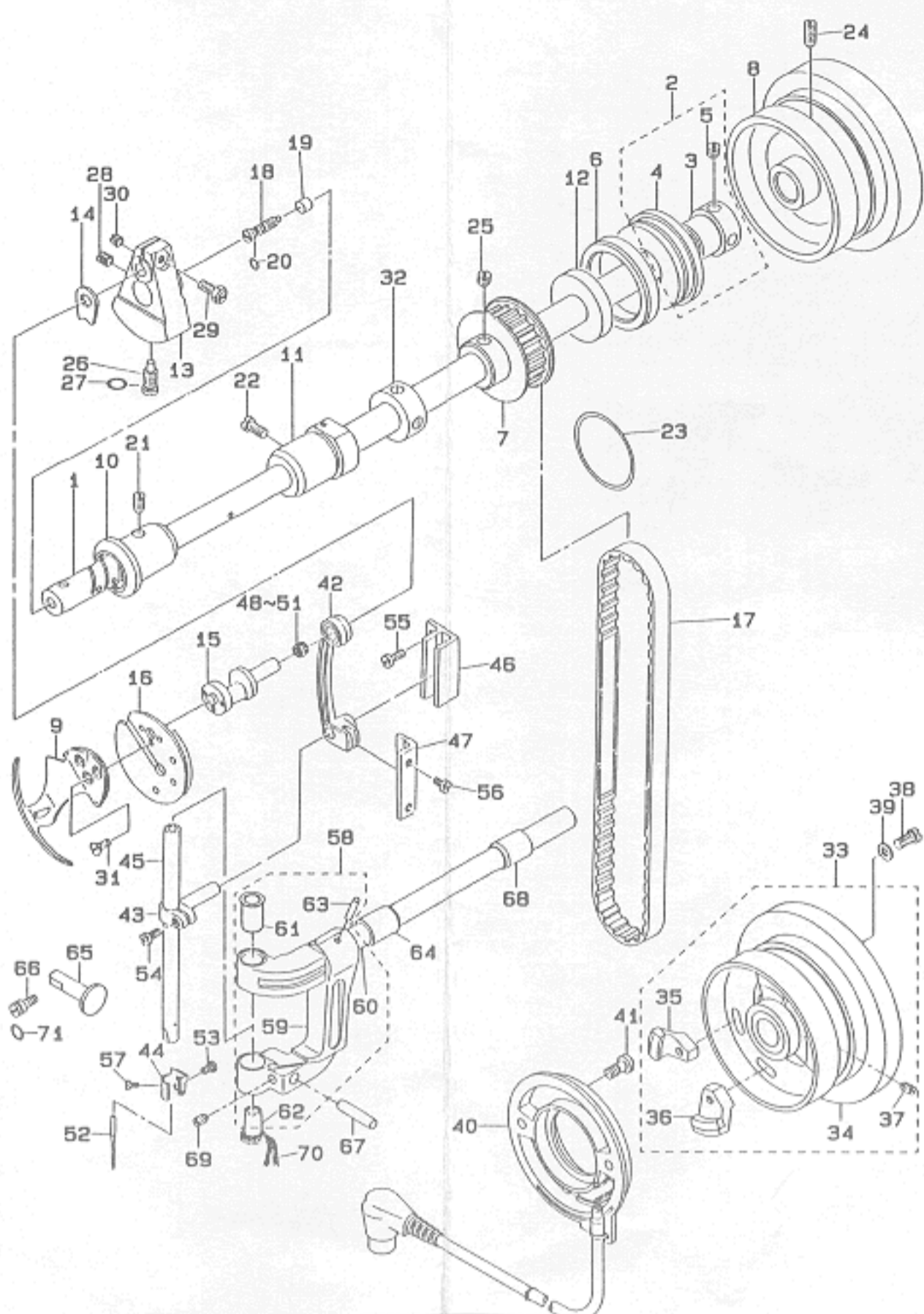

REF. NO	NOTE	PART NO.	DESCRIPTION	ANT.
1		225-05101	MAIN SHAFT	1
2		225-05259	THRUST COLLAR ASM.	1
3		225-05200	THRUST COLLAR	(1)
4		SB-1200001-00	BEARING D=20X47	(1)
5		SS-8660610-TP	SCREW 1/4-40 L=6	(2)
6		225-05309	OIL SEAL COLLAR	1
7		225-05408	SPROCKET	1
8		225-05507	HAND WHEEL	1
9		225-06109	BALANCE	1
10		100-08100	MAIN SHAFT BUSHING, FRONT	1
11		B1203-227-000-A	MAIN SHAFT BUSHING, INTERMEDIA	1
12		B1208-552-000-A	OIL SEAL	1
13		100-08407	COUNTERWEIGHT	1
14		100-08506	COUNTERWEIGHT PROTECTING PLATE	1
15		100-08605	TAKE-UP COUNTERWEIGHT ASM.	1
16		100-08753	TIMING BELT	1
17		100-09009	TIMING BELT	1
18		100-35608	PIN	1
19		B1810-552-000	OIL WICK	1
20		RO-0291801-00	RUBBER RING	1
21		SS-8151150-SP	SCREW 15/64-28 L=10.5	1
22		SS-7151120-SP	SCREW 15/64-28 L=11	1
23		RO-4372002-00	RUBBER RING	1
24		SS-8151550-SP	SCREW 15/64-28 L=15	2
25		SS-8660610-TP	SCREW 1/4-40 L=6	2
26		SS-7681650-TP	SCREW 9/32-28 L=16	1
27		RO-0442401-00	RUBBER RING	1
28		SS-8680730-SP	SCREW 9/32-28 L=7	1
29		SS-9661230-CP	SCREW 1/4-40 L=12	1
30		SS-8660610-TP	SCREW 1/4-40 L=6	1
31		SS-1090930-SP	SCREW 9/64-40 L=8.6	3
32		CS-147121A-SH	THRUST COLLAR ASM. D=14.72 W=12	1
33	#02	225-51568	HAND WHEEL ASM.	1
34	#02	225-51550	HAND WHEEL COMPL.	1
35	#02	M4007-110-0AB	MAGNET FITTING BASE B ASM.	1
36	#02	M4007-110-0AA	MAGNET FITTING BASE A ASM.	1
37		SS-8151550-SP	SCREW 15/64-28 L=15	2
38	#02	SS-6111210-SP	SCREW 11/64-40 L=12	2
39	#02	WP-0450801-SD	WASHER 4.5X10.0X0.8	2
40	#02	110-32562	GENERATOR STARTER ASM.	1
41	#02	106-04809	SCREW	2
42		225-07156	NEEDLE BAR CRANK ROD ASM.	1
43		225-07305	NEEDLE BAR CONNECTION	1
44		225-07404	THREAD RACK	1
45		225-07503	NEEDLE ROD	1
46		100-10304	GUIDE BLOCK	1
47		100-10502	CRANK ROD GUIDE	1
48	#01	B1905-541-A00	NEEDLE BEARING	1
49	#01	B1905-541-B00	BALANCE NEEDLE BEARING	1
50	#01	B1905-541-C00	NEEDLE BEARING	1
51	#01	B1905-541-D00	NEEDLE BEARING	1
52		HC-1918F07-50	NEEDLE (SY1965 75)	1
53		SS-7080520-SP	SCREW 1/8-44 L=4.9	1
54		SS-7090910-TP	SCREW 9/64-40 L= 8.5	1
55		SS-4110915-SP	SCREW 11/64-40 L=9	2
56		SS-4110715-SP	SCREW 11/64-40 L=7	2
57		SS-7060310-SP	SCREW 3/32-56 L=3	1
58		225-09152	NEEDLE BAR YOKE ASM.	1
59		225-09103	NEEDLE BAR YOKE	(1)
60		225-09202	SHAFT	(1)
61		100-13019	NEEDLE BAR BUSHING, UPPER D=7.	(1)
62		100-13118	NEEDLE BAR BUSHING, LOWER D=7.	(1)
63		PS-0400202-KH	SPRING PIN 4X20	(1)
64		110-10907	FEED ROCKER SHAFT BUSHING	1
65		225-09400	NEEDLE BAR YOKE PRESSER	1
66		225-09509	SCREW	1
67		100-13407	GUIDE PIN	1
68		100-13803	SHAFT BUSHING, REAR	1
69		SS-8120740-SP	SCREW 3/16-28 L=7	1
70		CQ-2020000-00	OIL WICK	0.1
71		RO-0481901-00	RUBBER RING	1

Note (注記) #01...SELECTIVE PART

#02...FOR LZ-2280-7, LZ-2286-7

5. NEEDLE VIBRATOR & ADJUSTMENT COMPONENTS (1)

針振り調節関係 (1)

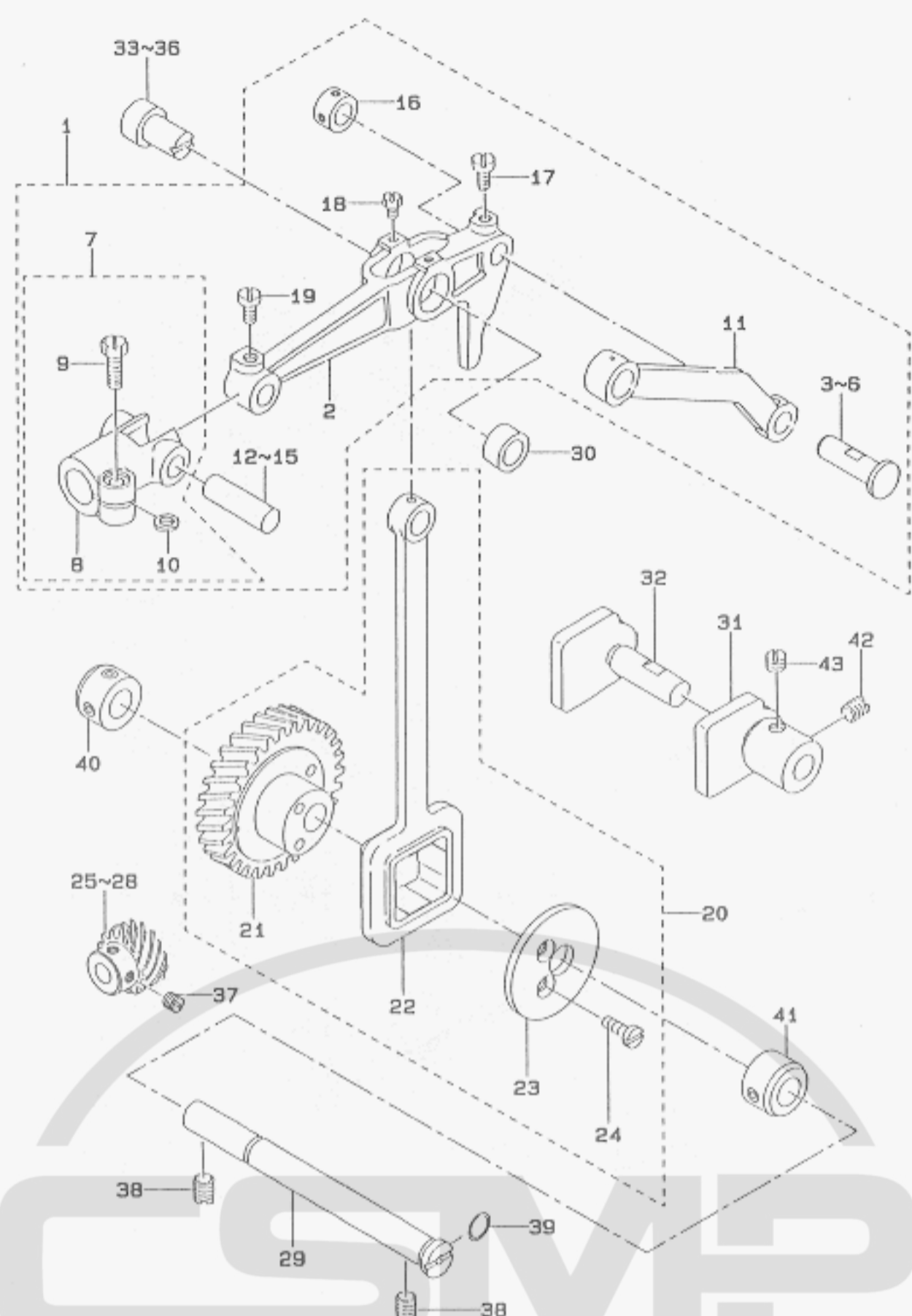

REF. NO	NOTE	PART NO.	DESCRIPTION	AMT.
1		225-09756	DRIVE LINK ASM.	1
2		225-09707	DRIVE LINK	(1)
3	#01	225-13105	LINK	(1)
4	#01	225-12909	SHAFT	(1)
5	#01	225-13006	SHAFT	(1)
6	#01	225-13204	SHAFT	(1)
7		225-09657	SHAFT CONNECTION ASM.	(1)
8		225-09608	SHAFT CONNECTION	(1)
9		SS-7121410-TP	SCREW 3/16-28 L=14	(1)
10		WP-0510516-SD	WASHER 5.1X7.5X0.5	(1)
11		100-16608	LINK	(1)
12	#01	100-12904	PIN D	(1)
13	#01	100-12607	PIN	(1)
14	#01	100-12706	PIN B	(1)
15	#01	100-12805	PIN C	(1)
16		CS-0790720-TH	THRUST COLLAR ASM.	(1)
17		SS-7110910-TP	SCREW 11/64-40 L= 8.5	(1)
18		SS-9090610-TP	SCREW 9/64-40 L=5.5	(2)
19		SS-7110910-TP	SCREW 11/64-40 L= 8.5	(1)
20		225-10051	NEEDLE VIBRATING CAM ASM.	1
21		225-10002	NEEDLE VIBRATING CAM	(1)
22		225-10101	NEEDLE VIBRATING ROD	(1)
23		225-10200	CAM COVER	(1)
24		SS-2110920-TP	SCREW 11/64-40 L=8.5	(2)
25	#01	100-11005	SCREW GEAR A	1
26	#01	100-11104	SCREW GEAR B	1
27	#01	100-11203	SCREW GEAR C	1
28	#01	100-11302	SCREW GEAR D	1
29		100-11500	SHAFT	1
30		100-12201	BUSHING	1
31		100-12409	DRIVE LINK GUIDE A	1
32		100-12508	DRIVE LINK GUIDE B	1
33	#01	100-11807	PIN	1
34	#01	100-11906	PIN B	1
35	#01	100-12003	PIN C	1
36	#01	100-12102	PIN D	1
37		SS-8660610-TP	SCREW 1/4-40 L=6	2
38		SS-8660970-TP	SCREW 1/4-40 L= 8.5	2
39		RO-0691801-00	RUBBER RING	1
40		CS-1031210-SH	THRUST COLLAR ASM. D=10.32 W=1	1
41		CS-103121B-SH	THRUST COLLAR ASM. D=10.32 W=1	1
42		SS-8150710-SP	SCREW 15/64-28 L=7	1
43		SS-8150410-SP	SCREW 15/64-28 L=4	1

Note (注記) #01...SELECTIVE PART

6. NEEDLE VIBRATOR & ADJUSTMENT COMPONENTS (2)

針振り調節関係 (2)

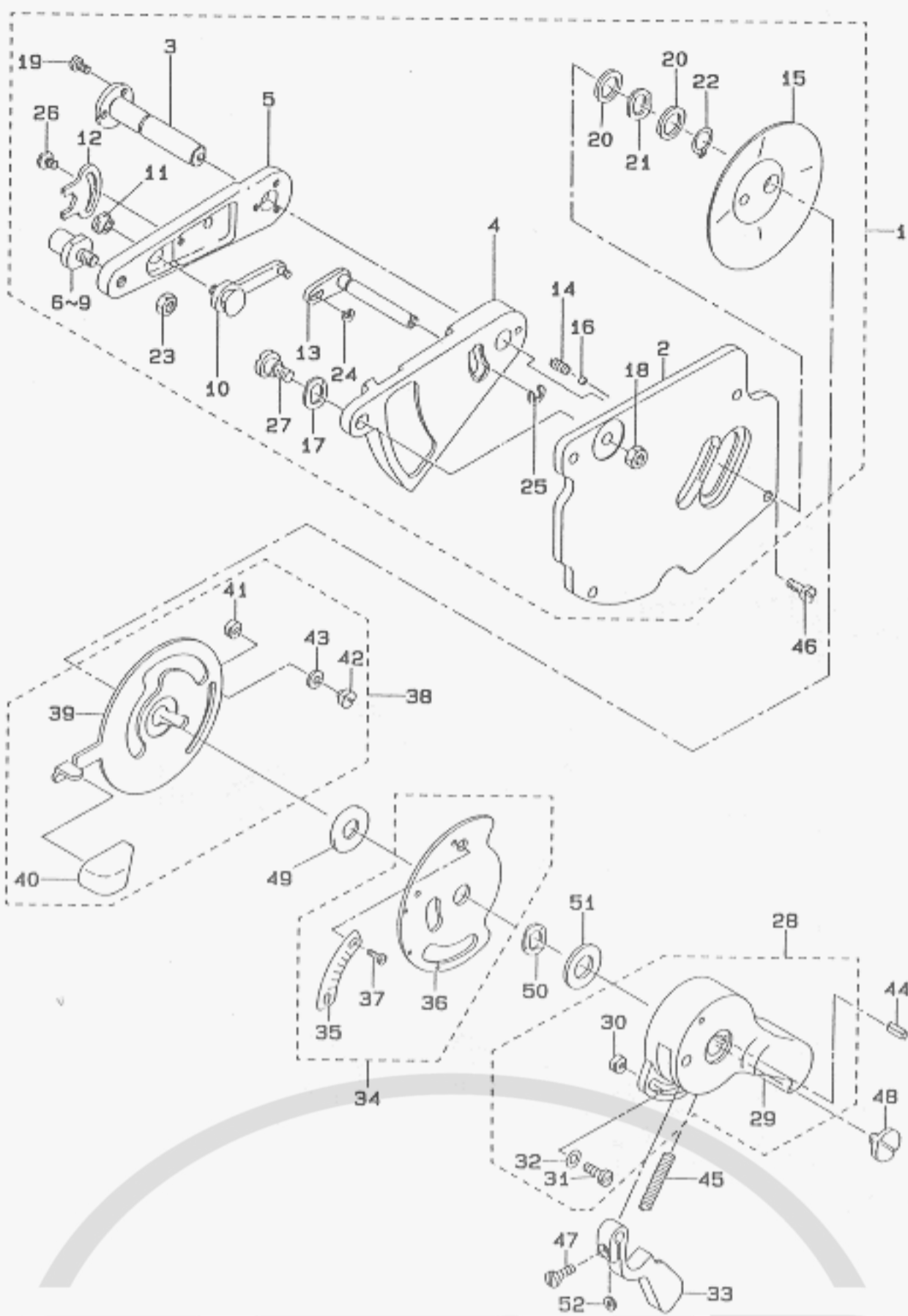

REF.NO	NOTE	PART NO.	DESCRIPTION	AMT.
1		225-12057	BASE ASH.	1
2		225-12008	BASE MOUNTING PLATE	(1)
3		225-12701	SHAFT	(1)
4		100-17317	NEEDLE POSITION ADJUSTING BASE	(1)
5		100-16012	ARM	(1)
6	#01	100-16517	SHAFT	(1)
7	#01	100-16210	SHAFT	(1)
8	#01	100-16319	SHAFT	(1)
9	#01	100-16418	SHAFT	(1)
10		100-17168	STOPPER ASM.	(1)
11		100-18000	NUT	(1)
12		100-18109	NUT STOPPER	(1)
13		100-15360	LEVER ASH.	(1)
14		100-17408	SPRING	(1)
15		100-17606	OIL SHIELD	(1)
16		B2608-761-000	HAND STOP CRANK SHAFT BALL	(1)
17		WZ-0850302-K0	WAVED WASHER 8.5X12.5X0.3	(3)
18		NS-6150310-SP	NUT 15/64-28	(1)
19		SS-6090620-SP	SCREW 9/64-40 L=6	(3)
20		WP-1020616-SD	WASHER	(2)
21		WZ-1052010-KP	WAVED WASHER	(1)
22		RC-0100001-KP	SNAP RING M10	(1)
23		NS-6150310-SP	NUT 15/64-28	(1)
24		RE-0200000-K0	E-RING	(1)
25		RE-0400000-K0	E-SHAPED SNAP RING (4MM)	(1)
26		SS-6090520-SP	SCREW 9/64-40 L= 5.0	(1)
27		SD-0800402-TP	HINGE SCREW D= 8 H= 4	(1)
28		225-12156	KNOB ASH.	1
29		225-12107	KNOB	(1)
30		100-15907	LEVER STOPPER	(2)
31		SS-4090610-SP	SCREW 9/64-40 L=6	(2)
32		WP-0371016-SD	WASHER 3.7X8X1	(2)
33		225-12206	LEVER	1
34		225-12354	SCALE PLATE ASH.	1
35		225-12305	SCALE PLATE	(1)
36		225-12453	SCALE MOUNTING BASE ASM.	(1)
37		SS-6080320-SP	SCREW 1/8-44 L= 2.5	(2)
38		225-12552	LEVER ASH.	1
39		225-12503	LEVER	(1)
40		225-12602	KNOB	(1)
41		100-15907	LEVER STOPPER	(2)
42		SS-7090410-SP	SCREW 9/64-40 L= 3.5	(2)
43		WP-0371016-SD	WASHER 3.7X8X1	(2)
44		100-15105	KEY	1
45		100-17705	SPRING	1
46		SS-4121015-SP	SCREW 3/16-28 L=10	4
47		SS-7090910-TP	SCREW 9/64-40 L= 8.5	1
48		SS-7620750-SP	SCREW 3/16-32 L= 0.5	1
49		WP-1021016-SD	WASHER	1
50		WZ-1052010-KP	WAVED WASHER	1
51		WP-1020616-SD	WASHER	1
52		WP-0371036-SD	WASHER 3.7X6X1	1

Note (注記) #01...SELECTIVE PART

7. PRESSER BAR & FEED REGULATOR COMPONENTS

押さえ棒・送り調節関係

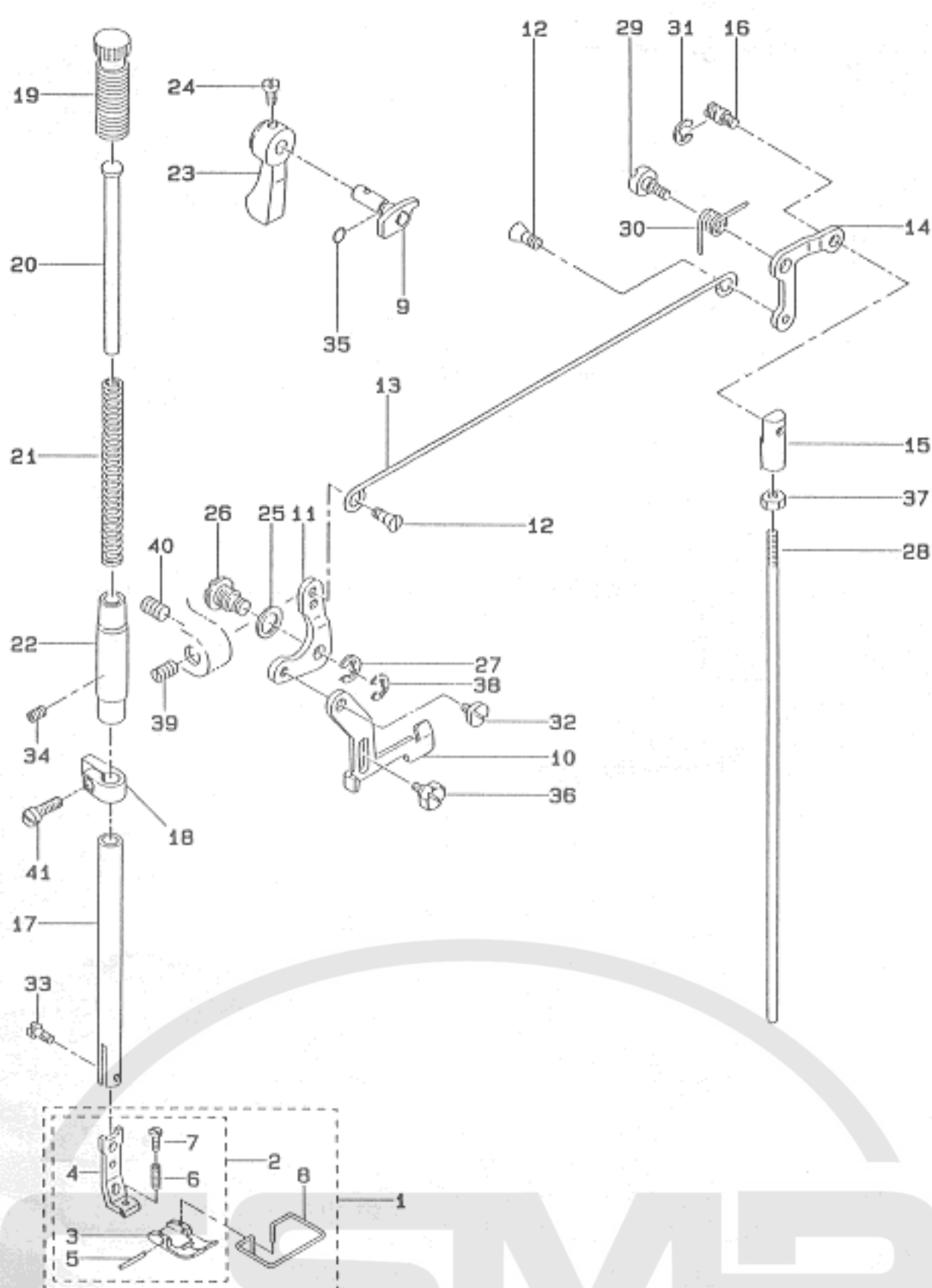

REF.NO	NOTE	PART NO.	DESCRIPTION	AMT.
1	#01	225-45362	PRESSER FOOT ASM.	1
2	#01	225-45354	PRESSER FOOT ASM.	(1)
3		225-45305	PRESSER FOOT (LOWER)	(1)
4		225-45206	PRESSER FOOT (UPPER)	(1)
5		100-21103	PRESSER PIN	(1)
6		B1525-582-000	SPRING	(1)
7		SS-6090810-SP	SCREW 9/64-40 L= 7.5	(1)
8		225-45404	SAFETY COVER	(1)
9		225-15357	HAND LIFTER CAM COMPL.	1
10		100-22408	LIFTING LEVER	1
11		B1516-552-000	LIFTING LEVER LINK	1
12		110-07101	HINGE SCREW	2
13		110-06905	LIFTING LEVER CONNECTING ROD	1
14		B3414-555-000	LIFTING LEVER LINK ARM	1
15		B3416-555-000	SWIVEL	1
16		B3416-552-000	CONNECTING ROD HINGE SCREW	1
17		100-22010	PRESSER BAR	1
18		100-22309	PRESSER BAR GUIDE BRACKET	1
19		110-71602	PRESSER SPRING REGULATOR	1
20		B1510-227-000	PRESSER GUIDE BAR	1
21		B1505-227-000-A	PRESSER SPRING	1
22		B1502-541-000	PRESSER BAR BUSHING, LOWER	1
23		110-71800	HAND LIFTER	1
24		B1521-555-000	SCREW	1
25		B3431-581-000	LIFTING LEVER GASKET	1
26		B1517-552-000	HINGE PIN	1
27		B1523-226-000	SNAP RING	1
28		100-22606	CONNECTING ROD, VERTICAL	1
29		GAK-33041000	KNEE LIFTING LINK STEP-SCREW	1
30		GAK-33042000	KNEE LIFTING LINK SPRING	1
31		RE-0500000-KO	E-RING	1
32		SD-0630301-SP	HINGE SCREW D=6.35 H=3	1
33		SS-7090910-SP	SCREW 9/64-40 L= 8.5	1
34		SS-8150710-SP	SCREW 15/64-28 L=7	1
35		RO-0371801-00	RUBBER RING	1
36		SD-0630275-SP	HINGE SCREW D= 6.35 H= 2.7	1
37		NS-6620310-SP	NUT 3/16-32	1
38		RE-0600000-KO	E-SHAPED SNAP RING (6WH)	1
39		SS-8151720-SP	SCREW	1
40		SS-8150510-TP	SCREW 15/64-28 L= 4.7	1
41		SS-7111110-TP	SCREW 11/64-40 L=10.5	1

Note (注記) #01...NO NECESSARY PART ACCORDING TO DESTINATIONS

8. FEED MECHANISM & CONDENSE COMPONENTS

送り機構・コンデンス装置関係

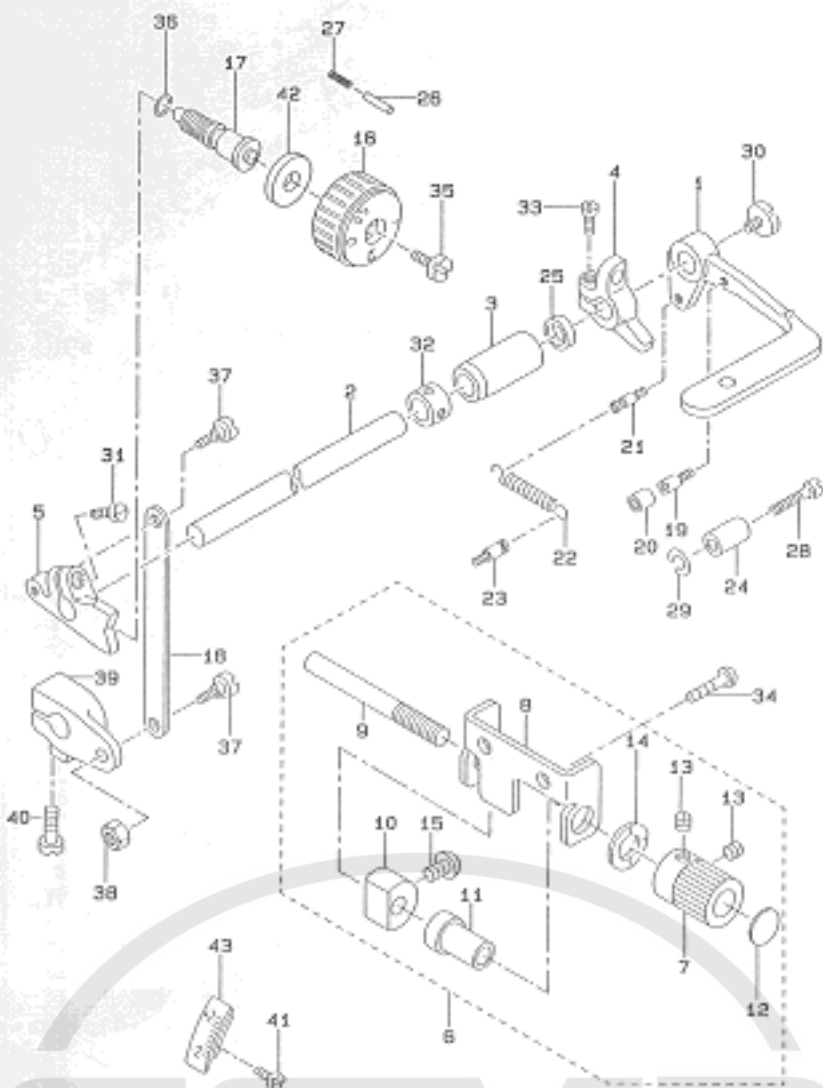

REF. NO	NOTE	PART NO.	DESCRIPTION	AMT.
1		225-18005	LEVER	1
2		225-18104	SHAFT	1
3		225-18203	BUSHING	1
4		225-18351	CONDENSE STOPPER ARM ASM.	1
5		225-18401	FEED DRYING ADJUSTER	1
6		225-18559	KNOB ASM.	1
7		225-18500	KNOB	(1)
8		225-18609	ADJUSTING SCREW BASE	(1)
9		225-18708	ADJUSTING SCREW	(1)
10		225-18807	STOPPERE	(1)
11		225-18906	SHAFT	(1)
12		112-12503	STOPPER DIAL PLATE	(1)
13		SS-8110410-TP	SCREW 11/64-40 L= 3.5	(2)
14		WZ-1052010-KP	WAVED WASHER	(1)
15		SS-4110715-SP	SCREW 11/64-40 L=7	(1)
16		225-19102	DIAL	1
17		225-19201	ADJUSTING SCREW	1
18		225-19300	FEED REVERSAL LINK	1
19		B1114-280-000	PIN	1
20		101-19907	CUSHION	1
21		101-20004	SPRING SUSPENSION	1
22		D2515-232-D00	TORSION SPRING	1
23		B1631-012-B00	SUSPENSION STUD B	1
24		111-00500	REVERSE FEED LEVER STOPPER	1
25		B2508-704-000	OIL SEAL	1
26		110-52701	PIN	1
27		B1148-555-000	SPRING	1
28		SS-0121840-SP	SCREW 3/16-28 L=18.0	1
29		VS-0510002-KP	SPRING WASHER	1
30		SS-7020750-SP	SCREW 3/16-32 L= 0.5	1
31		SS-7121410-TP	SCREW 3/16-28 L=14	1
32		CS-1031210-SH	THRUST COLLAR ASM. D=10.32 V=1	1
33		SS-7121410-TP	SCREW 3/16-28 L=14	1
34		SS-4120615-SP	SCREW 3/16-28 L=6	2
35		SS-0121800-SP	SCREW	1
36		RO-0742401-00	RUBBER RING	1
37		SD-0600321-SP	HINGE SCREW D=0 H=3.2	2
38		NS-0120310-SP	NUT 3/16-28	1
39		100-28900	FEED VARIABLE ARM B	1
40		SS-0121610-TP	SCREW 3/16-28 L=15.5	1
41		SS-4120615-SP	SCREW 3/16-28 L=6	2
42		D2408-555-B00	RUBBER PLUNGER	1
43		225-19805	SCALE PLATE	1

9. FEED MECHANISM COMPONENTS

送り関係

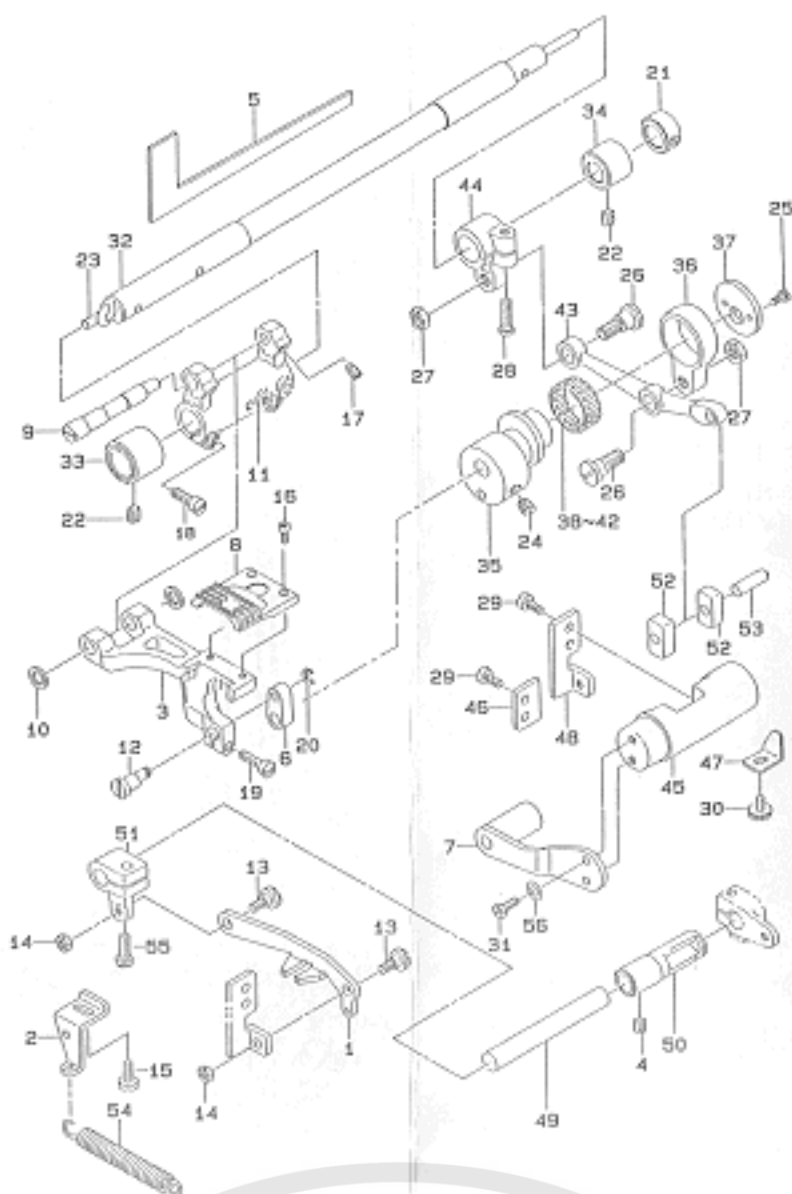

REF.NO	NOTE	PART NO.	DESCRIPTION	QTY.
1		225-19508	FEED REVERSAL LINK	1
2		225-19607	TENSION SPRING RACK	1
3		225-19700	FEED-BASE	1
4		SS-8150710-SP	SCREW 15/64-28 L=7	1
5		225-19904	FELT	1
6		225-20001	LINK	1
7		225-20159	BALANCE WEIGHT COMPL.	1
8		225-45107	FEEDER	1
9		100-26102	ECCENTRIC SHAFT	1
10		100-26201	SPACER	2
11		100-26300	FEED ROCKER	1
12		100-26508	LINK PIN	1
13		SD-0000321-SP	HINGE SCREW D=6 H=3.2	2
14		NS-6120310-SP	NUT 3/16-28	2
15		SS-6111140-SP	SCREW 11/64-40 L=11	1
16		SS-6580752-TP	SCREW 1/8-40 L=7	2
17		SS-8120740-SP	SCREW 3/16-28 L=7	2
18		SS-7121410-TP	SCREW 3/16-28 L=14	2
19		SS-7121410-TP	SCREW 3/16-28 L=14	1
20		RE-0300000-K0	E-SHAPED SNAP RING (3MM)	1
21		CS-1111010-SH	THRUST COLLAR ASM. D=11.11 W=1	1
22		SS-8150710-SP	SCREW 15/64-28 L=7	2
23		CQ-5006000-00	OIL WICK	0.4
24		SS-8660810-TP	SCREW 1/4-40 L=8	2
25		SS-4080610-SP	SCREW 1/8-44 L=6.4	2
26		SD-0000701-TP	HINGE SCREW D=9 H=7	2
27		NS-6680410-SP	NUT 9/32-28	2
28		SS-8121610-TP	SCREW 3/16-28 L=15.5	1
29		SS-6111010-SP	SCREW 11/64-40 L=9.5	4
30		SS-5110710-SP	SCREW 11/64-40 L=7	1
31		SS-9111020-TP	SCREW 11/64-40 L=10	2
32		100-26607	FEED ROCKER SHAFT	1
33		B1702-155-000	BUSHING, REAR	1
34		B1604-155-000	FEED ROCKER SHAFT BUSHING, FRD	1
35		100-26700	ECCENTRIC CAM	1
36		100-26805	ROD	1
37		100-26904	SIDE DISC PLATE	1
38	#01	B1609-804-A00	BUSHING	1
39	#01	B1609-804-B00	NEEDLE BEARING	1
40	#01	B1609-804-C00	BEARING	1
41	#01	B1609-804-D00	BEARING	1
42	#01	B1609-804-E00	BEARING	1
43		100-27001	CONNECTING ROD	1
44		100-27100	FEED ROCKER SHAFT CRANK	1
45		100-27209	FEED DRIVING ROCKER	1
46		100-27308	PLATE A	1
47		100-27506	STOPPER PLATE	1
48		100-27407	PLATE B	1
49		100-28702	FEED VARIABLE SHAFT	1
50		100-28801	BUSHING	1
51		100-29007	FEED VARIABLE ARM C	1
52		100-29001	FEED DRIVING ROCKER BLOCK	2
53		B1653-470-000	PIN	1
54		B1646-555-000	TENSION SPRING	1
55		SS-7121410-TP	SCREW 3/16-28 L=14	1
56		WP-0450000-SD	WASHER 4.5X8X0.5	2

Note (注記) #01...SELECTIVE PART

10. LUBRICATION COMPONENTS

給油関係

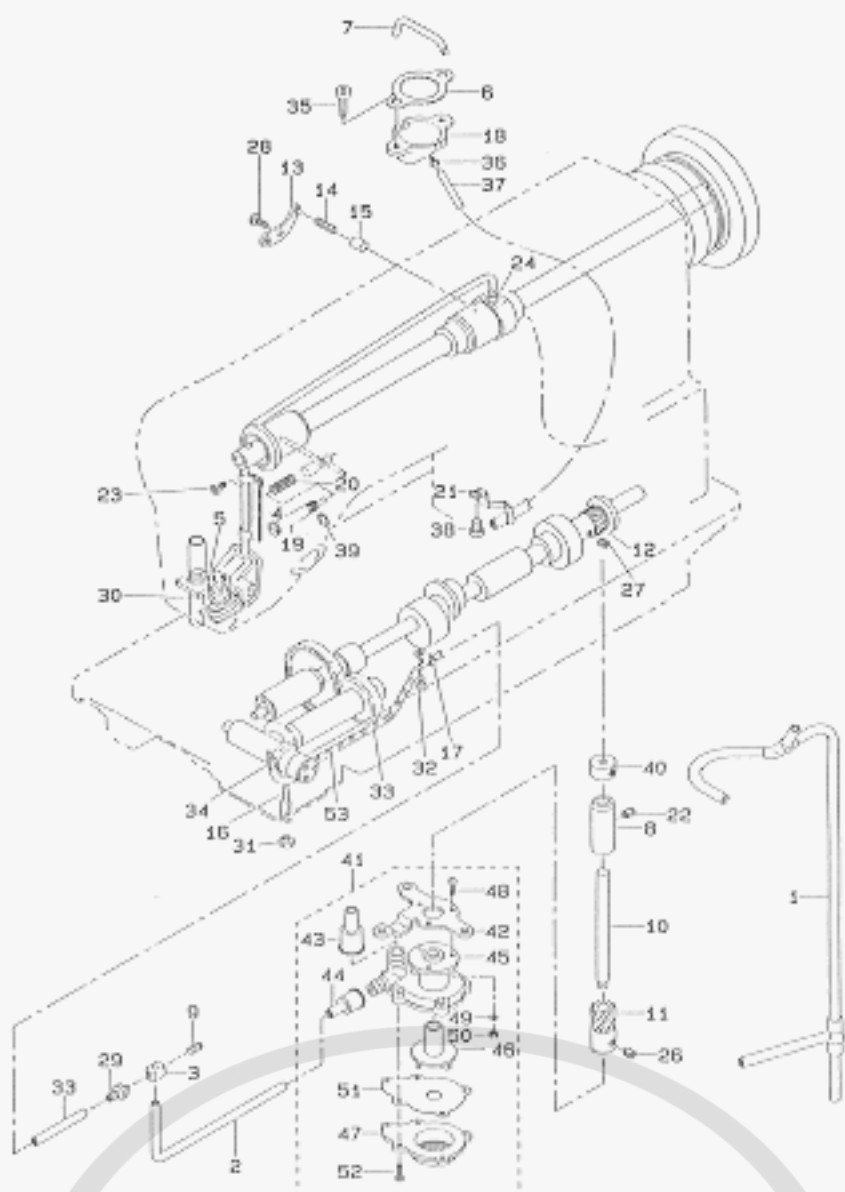

REP. NO	NOTE	PART NO.	DESCRIPTION	ANT.
1		225-31156	OIL SUPPLY PIPE ASH.	1
2		225-31206	OIL SUPPLY PIPE	1
3		225-31305	DISTRIBUTOR	1
4		225-31552	FELT ASH.	1
5		225-31701	FELT PRESSER	1
6		225-31909	GASKET	1
7		225-32006	OIL TUBE	1
8		100-35301	BUSHING	1
9		SS-8110510-SP	SCREW 11/64-40 L=5	1
10		B1301-555-000	UPRIGHT SHAFT	1
11		100-35111	PUMP DRIVING GEAR	1
12		100-35004	PUMP DRIVING GEAR A	1
13		B3524-552-000	PLUNGER THRUST PLATE	1
14		B1214-038-000	PLUNGER SPRING	1
15		B3534-155-000	PLUNGER	1
16		100-37100	OIL REGULATING SCREW	1
17		B3538-112-000	CURD HOLDER	1
18		101-25004	OIL TANK	1
19		100-35707	OIL REGULATING SCREW	1
20		B2510-372-000	SPRING	1
21		B3565-771-000	OIL FELT GUIDE	1
22		SS-8150710-SP	SCREW 15/64-28 L=7	1
23		SS-4110715-SP	SCREW 11/64-40 L=7	1
24		SQ-1110402-HZ	CONNECTING SCREW	1
25		SS-6111140-SP	SCREW 11/64-40 L=11	2
26		SS-8660530-TP	SCREW 1/4-40 L= 4.5	2
27		SS-8660530-TP	SCREW 1/4-40 L= 4.5	2
28		SS-4110715-SP	SCREW 11/64-40 L=7	1
29		SQ-1110402-HZ	CONNECTING SCREW	1
30		CQ-2020000-00	OIL WICK	0.2
31		NS-6150310-SP	NUT 15/64-28	1
32		SS-4110515-SP	SCREW 11/64-40 L=5	1
33		BT-0500300-EA	OIL TUBE	0.4
34		SQ-1110402-HZ	CONNECTING SCREW	2
35		SS-4111215-SP	SCREW 11/64-40 L=12	2
36		SO-1150451-HZ	CONNECTING SCREW	1
37		BT-0600402-EA	LUBRICATING PIPE	0.3
38		SS-4110515-SP	SCREW 11/64-40 L=5	1
39		RO-0201801-00	RUBBER RING	1
40		CS-070073A-SH	THRUST COLLAR	1
41		B3501-555-0A0	OIL WICK	1
42		B3503-555-000	OIL PUMP INSTALLING BASE	(1)
43		B3505-555-000	RUBBER JOINT	(1)
44		B3506-555-000	RUBBER JOINT	(1)
45		B3501-555-000	LUBRICATING OIL PUMP	(1)
46		B3507-555-000	OIL PUMP IMPELLER	(1)
47		B3508-555-000	OIL PUMP IMPELLER COVER	(1)
48		SH-4031001-SC	SCREW M3X0.5 L=10	(3)
49		WT-0320002-KZ	WASHER	(3)
50		NH-6030000-0E	NUT M3X0.5	(3)
51		B3502-555-000	LUBRICATING OIL PUMP COVER	(3)
52		SE-4301031-SR	SCREW	(5)
53		CQ-2020000-00	OIL WICK	0.3

11. THREAD TRIMMER MECHANISM COMPONENTS (FOR LZ-2280-7)

糸切り関係 (LZ-2280-7 専用部品)

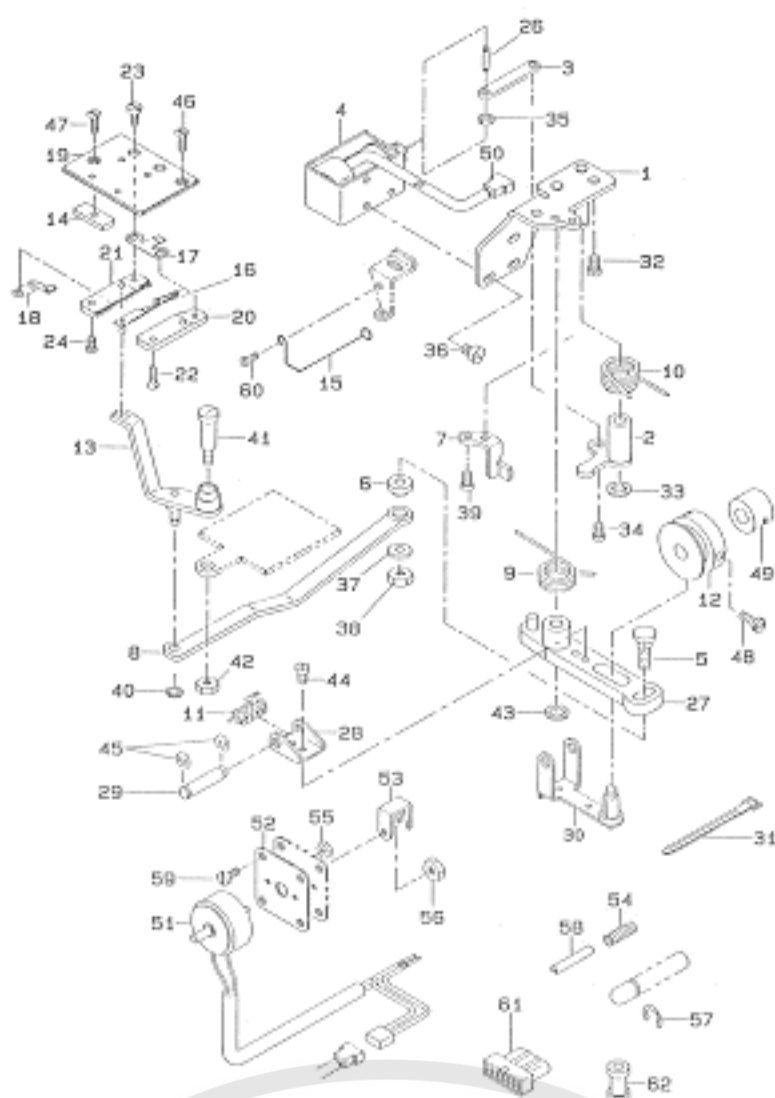

REF. NO.	NOTE	PART NO.	DESCRIPTION	QTY.
1		225-54158	BASE PLATE ASM.	1
2		225-54356	CLUTCH PLATE ASM.	1
3		225-54505	CLUTCH LINK	1
4		225-54604	MAGNET	1
5		225-54703	MOVING KNIFE LINK PIN	1
6		225-54802	MOVING KNIFE LINK BASE	1
7		225-54901	DRIVING ARM STOPPER	1
8		225-55007	MOVING KNIFE LINK	1
9		225-55100	KNIFE RETURN SPRING	1
10		225-55205	CLUTCH SPRING	1
11		225-55304	ROLLER RETURN SPRING	1
12		225-55403	THREAD CUTTING CAM	1
13		225-55551	FORK KNIFE ASM.	1
14		225-56906	FIXED PLATE	1
15		225-57003	CORD PRESSER	1
16		225-56153	DRIVING KNIFE ASM.	1
17		225-56302	FIXED KNIFE	1
18		225-56450	CLAMP PLATE ASM.	1
19		225-56609	SLIDING PLATE	(1)
20		225-56708	DRIVING BASE	(1)
21		225-56807	DRIVING BASE	(1)
22		SS-1000510-SP	SCREW 9/64-40 L=5	(2)
23		SS-6000420-SP	SCREW 9/64-40 L= 4.0	(2)
24		SS-7000710-SP	SCREW 9/64-40 L= 6.8	(2)
25		WP-0370310-SD	WASHER 3.2X8X0.3	(1)
26		D2107-555-B00	WIPER LINK SHAFT, A	1
27		110-40854	KNIFE DRIVING ARM ASM.	1
28		110-41308	ROLLER ARM BRACKET	1
29		110-41407	ROLLER FULCRUM SHAFT	1
30		110-93358	ROLLER ARM ASM.	1
31		EA-9500801-00	CABLE BAND	2
32		SS-4150915-SP	SCREW 15/64-28 L=9	2
33		RE-0800000-K0	E-SHAPED SNAP RING (6MM)	1
34		SD-0600201-TP	HINGE SCREW D=6 H=2.9	1
35		RE-0250000-K0	E-SHAPED SNAP RING (2.5MM)	2
36		SH-4040601-SH	SCREW M4 L=6	3
37		WP-0621016-SH	WASHER	1
38		NS-6150430-SP	NUT 15/64-28	1
39		SS-4110915-SP	SCREW 11/64-40 L=9	2
40		RE-0500000-K0	E-RING	1
41		SD-0701503-SP	HINGE SCREW D=7.94 H=15	1
42		NS-6150310-SP	NUT 15/64-28	1
43		RE-0800000-K0	E-SHAPED SNAP RING (6MM)	1
44		SS-7090610-SP	SCREW 9/64-40 L=6	1
45		RE-0400000-K0	E-SHAPED SNAP RING (4MM)	1
46		SS-2110915-SP	SCREW 11/64-40 L=6.8	1
47		SS-2111010-TP	SCREW 11/64-40 L=9.5	1
48		SS-6060710-TP	SCREW 1/4-40 L=7	1
49		CS-0951010-SH	THRUST COLLAR ASM. D=9.53 W=10	1
50		HK-0044300-2A	HOUSING 2P	1
51		225-52756	SCREW 9/64-40 L=14	1
52		225-52806	SOLENOID FITTING BASE	1
53		225-52905	THREAD RELEASE PUSH PLATE	1
54		D3133-555-B00	SPRING	1
55		NH-6030001-SC	NUT M3	2
56		NH-6040001-SH	NUT M4X0.7	1
57		RE-0400000-K0	E-SHAPED SNAP RING (4MM)	1
58		PS-0300182-KF	SPRING PIN 3X18	1
59		SS-4120615-SP	SCREW 3/16-28 L=6	4
60		SS-4110515-SP	SCREW 11/64-40 L=5	1
61		HK-0346101-40	HOUSING 14P	1
62		D2467-555-B00	RUBBER PLUG	2

12. UPPER THREAD FEEDER COMPONENTS (FOR LZ-2280-7)

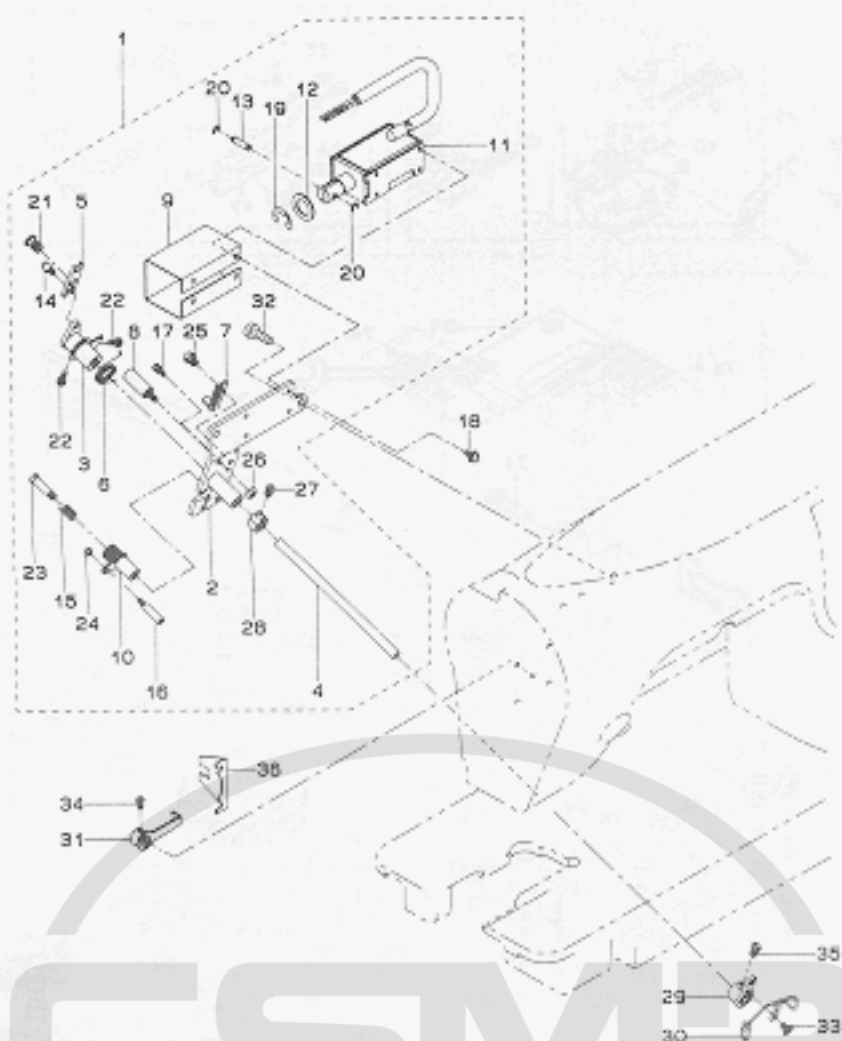

REF. NO	NOTE	PART NO.	DESCRIPTION	Qty
1		225-64157	THREAD FEEDER ASM.	1
2		225-64256	FITTING BASE COMPL.	(1)
3		225-64454	FEED LEVER COMPL.	(1)
4		225-64702	FEED LEVER SHAFT	(1)
5		225-64801	LINK	(1)
6		225-65204	FEED LEVER SPRING	(1)
7		225-65303	STOPPER	(1)
8		225-65402	SHAFT	(1)
9		225-65501	SOLENOID COVER	(1)
10		225-65659	PLATE	(1)
11		225-65857	SOLENOID COMPL.	(1)
12		112-34408	SOLENOID RUBBER	(1)
13		112-34507	PLUNGER CONNECTING PIN	(1)
14		B2560-372-000	BUTTON CLAMP STOP PIN	(1)
15		B2020-372-000	SPRING	(1)
16		B2034-372-000	THREAD RELEASING SCREW STUD	(1)
17		B2024-771-000	SUSPENSION SCREW	(1)
18		SL-4030881-SF	SCREW M3 X 8	(4)
19		RE-0900000-K0	SNAP RING 9.0	(1)
20		RE-0300000-K0	E-SHAPED SNAP RING (3MM)	(2)
21		SD-0640241-SP	HINGE SCREW D= 6.35 H= 2.4	(1)
22		SS-7110540-SP	SCREW 11/64-40 L=5	(2)
23		SD-0481451-SP	HINGE SCREW D= 4.80 H=14.5	(1)
24		NS-6080340-SP	NUT 1/8-44	(1)
25		SS-4120615-SP	SCREW 3/16-28 L=6	(1)
26		NS-6120310-SP	NUT 3/16-28	(1)
27		SS-7110540-SP	SCREW 11/64-40 L=5	(2)
28		CS-0640863-SH	THRUST COLLAR D=0.35 V=8	(1)
29		225-64959	FITTING PLATE COMPL.	1
30		225-65195	WIRE	1
31		225-66152	STOPPER PLATE COMPL.	1
32		SS-4120915-SP	SCREW 3/16-28 L=9	2
33		SS-0090540-SP	SCREW 9/64-40 L= 5.0	2
34		SS-9110620-TP	SCREW	2
35		SS-9090610-TP	SCREW 9/64-40 L=5.5	2
36		225-66301	STOPPER PLATE GUIDE	1

13. AUTOMATIC REVERSE FEED MECHANISM COMPONENTS
(FOR LZ-2280-7)

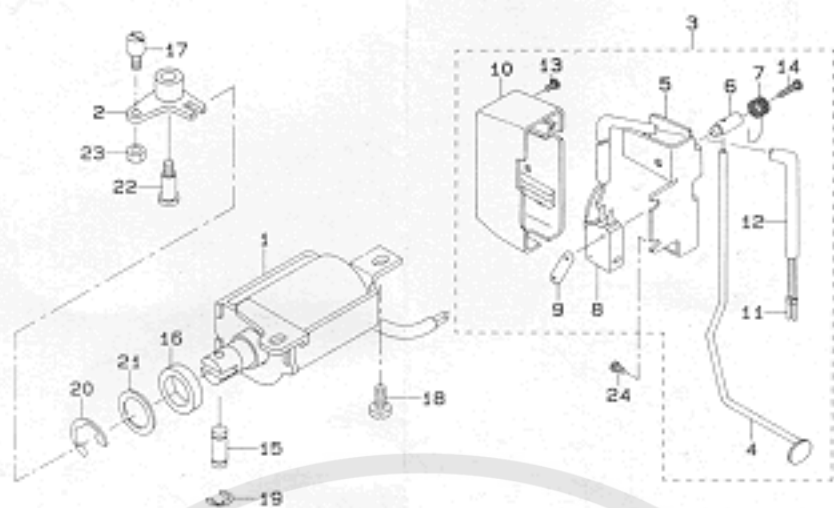

REF.NO	NOTE	PART NO.	DESCRIPTION	Qty
1		225-59058	MAGNET ASM.	1
2		225-59553	REVERSE FEED LINK ASM.	1
3		225-59850	REVERSE FEED SWITCH	1
4		225-59900	REVERSE FEED SWITCH LEVER	(1)
5		111-02001	REVERSE FEED SWITCH BASE	(1)
6		111-02100	REVERSE FEED SWITCH SHAFT	(1)
7		111-02209	REVERSE FEED SWITCH SPRING	(1)
8		HA-0019000-00	MICROSWITCH	(1)
9		111-02308	REVERSE FEED SWITCH PLATE	(1)
10		110-72501	REVERSE FEED SWITCH COVER	(1)
11		HK-0346400-08	PIN CONTACT	(2)
12		HW-5000700-00	2-CORE CABTYRE CORD	(1.5)
13		SS-4110615-SP	SCREW 11/64-40 L=6	(1)
14		SS-9111610-SP	SCREW 11/64-40 L=10	(1)
15		111-01003	PLUNGER ARM PIN	1
16		D2468-555-800	RUBBER PLUNGER	1
17		B1213-372-000	SCREW	1
18		SS-4150915-SP	SCREW 15/64-28 L=9	2
19		RE-0400000-K0	E-SHAPED SNAP RING (4MM)	2
20		RE-1200000-K0	SNAP RING 12	1
21		WP-1602616-SZ	WASHER 16X24X2.6	1
22		SD-0791503-SP	HINGE SCREW D=7.94 H=15	1
23		NS-6150310-SP	NUT 15/64-28	1
24		SS-4120615-SP	SCREW 3/16-28 L=6	2

14. WIPER MECHANISM COMPONENTS (FOR LZ-2280-7)

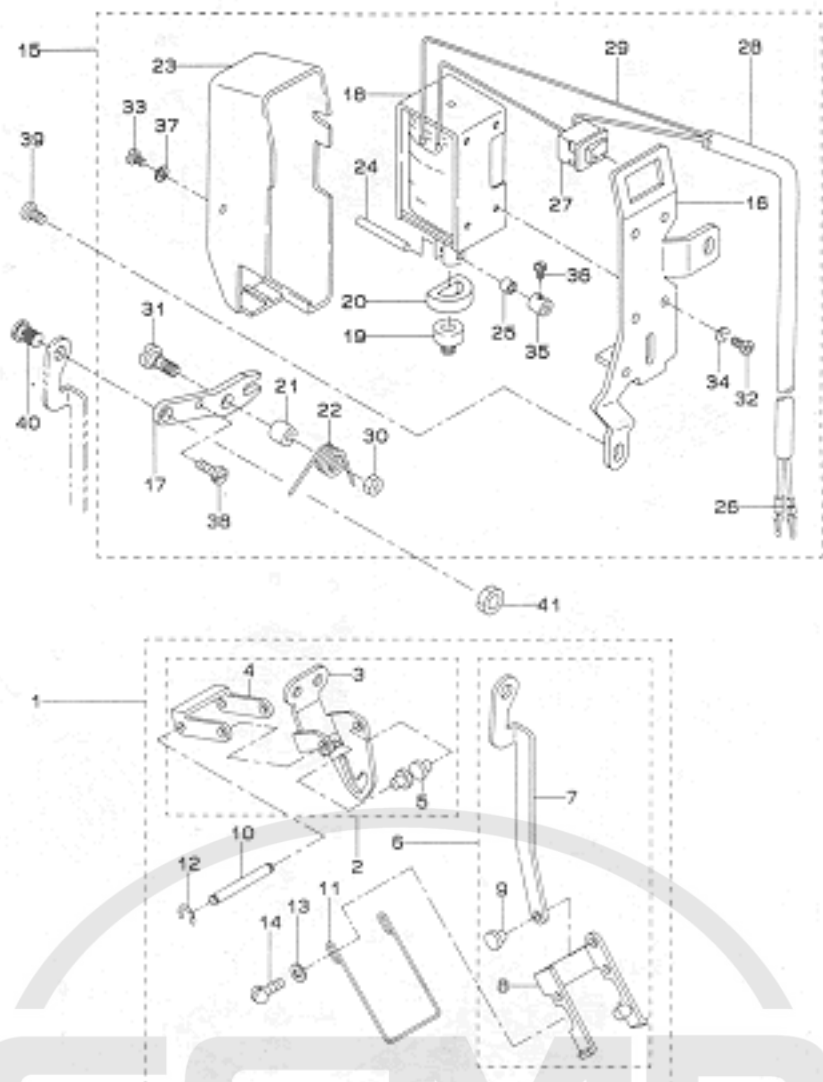

REF.NO	NOTE	PART NO.	DESCRIPTION	Qty
1		225-61757	WIPER ASM.	1
2		225-61856	WIPER BASE ASM.	(1)
3		225-61807	WIPER BASE	(1)
4		102-08601	WIPER LINK 1	(1)
5		D2107-490-000	PIN	(2)
6		225-61955	WIPER LINK COMPL.	(1)
7		225-61906	WIPER LINK	(1)
8		102-08858	WIPER LINK ASM. 2	(1)
9		D2107-490-000	PIN	(1)
10		102-08700	WIPER LINK SHAFT	(1)
11		225-61708	WIPER	(1)
12		RE-0320000-K0	SNAP RING 3.2	(2)
13		WP-0371016-SD	WASHER 3.7X8X1	(2)
14		SS-3090520-SP	SCREW 9/64-40 L=4.5	(2)
15		225-62052	SOLENOID ASM.	1
16		225-62102	WIPER BASE	(1)
17		225-62201	WIPER LINK	(1)
18		111-10301	WIPER SOLENOID	(1)
19		111-10400	WIPER RUBBER A	(1)
20		111-10509	WIPER RUBBER B	(1)
21		111-10707	WIPER HINGE SCREW COLLAR	(1)
22		111-10806	WIPER SPRING	(1)
23		110-72709	WIPER COVER	(1)
24		111-11705	WIPER SOLENOID PIN	(1)
25		111-11804	WIPER LINK COLLAR	(1)
26		NK-0346400-0B	PIN CONTACT	(2)
27		HA-0005900-00	POWER SWITCH	(1)
28		HV-5000700-00	2-CORE CABTYRE CORD	(1.5)
29		HV-2003900-00	ELECTRIC WIRE	(0.1)
30		NS-6110310-SP	NUT 11/64-40	(1)
31		SD-0650321-TP	HINGE SCREW	(1)
32		SM-4030801-SN	SCREW M3 X 6	(4)
33		SM-4030801-SN	SCREW M3 X 6	(1)
34		WS-0310002-KN	SPRING WASHER M3	(4)
35		CS-0300711-SP	THRUST COLLAR	(1)
36		SS-6080320-SP	SCREW 1/8-44 L= 2.5	(2)
37		WP-0320501-SC	WASHER M3	(1)
38		SS-6111040-SP	SCREW 11/64-40 L= 9.5	(1)
39		SS-4120615-SP	SCREW 3/16-28 L=6	2
40		SD-0000271-SP	HINGE SCREW D= 6 H= 2.7	1
41		NS-6110310-SP	NUT 11/64-40	1

15. THREAD STAND COMPONENTS (1)

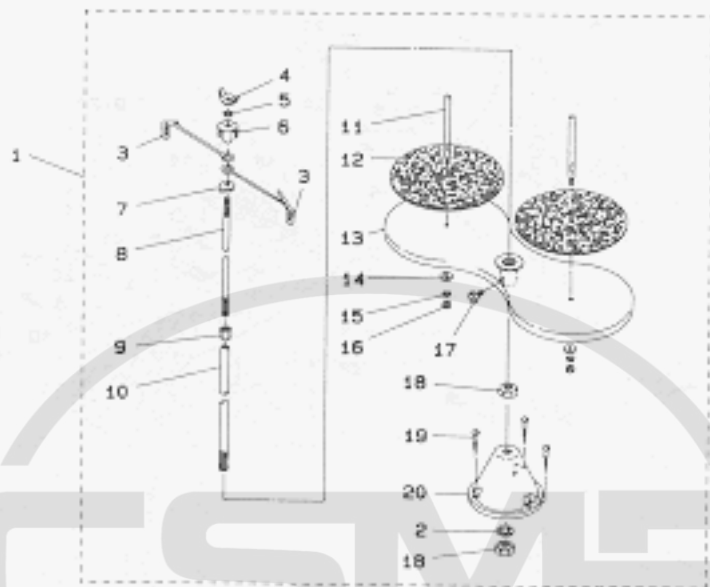

REF.NO	NOTE	PART NO.	DESCRIPTION	Qty
1		111-83167	THREAD STAND ASH.	1
2		WS-1002560-KR	SPRING WASHER 10X18X2.5	(1)
3		B3307-012-000	THREAD GUIDE	(2)
4		B8310-012-000	POSITION CUP SET SCREW	(1)
5		WS-0641560-KR	SPRING WASHER 6.4X11.9X1.5	(1)
6		B3309-012-000	POSITION CUP	(1)
7		B3308-012-000	ROD WASHER	(1)
8		B3306-012-000	SPOOL ROD	(1)
9		B3302-012-000	SPOOL REST ROD	(1)
10		111-84009	SPOOL RETAINER	(2)
11		B3320-704-L00-A	SPOOL PIN	(2)
12		B3311-012-000	SPOOL REST CUSHION	(2)
13		111-83209	SPOOL REST	(1)
14		WP-0560860-SE	WASHER 5.6X12X0.8	(2)
15		WS-0531060-KR	SPRING WASHER 5.3X8.3X1	(2)
16		NS-6123881-SE	NUT 3/16-28	(2)
17		SW-9061080-SE	SCREW M6 L=10	(1)
18		NW-6100603-SE	NUT M10	(2)
19		SK-3452000-SE	WOOD SCREW D=4.5 L=20	(3)
20		111-83100	THREAD STAND	(1)

16. THREAD STAND COMPONENTS(2)

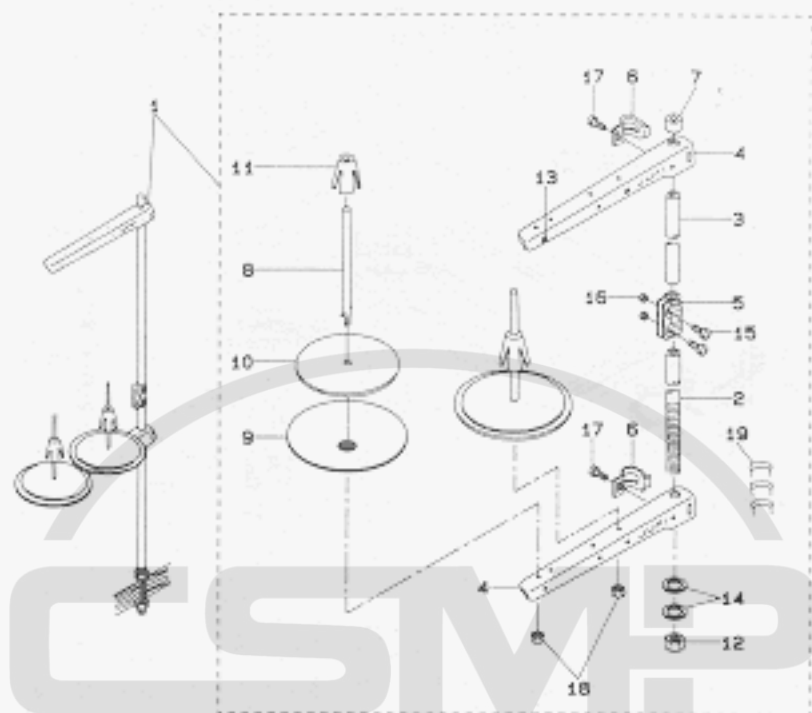

REF.NO	NOTE	PART NO.	DESCRIPTION	Qty
1		139-46751	THREAD STAND ASM.	1
2		111-85105	SPOOL REST ROD,LOWER	(1)
3		111-85204	SPOOL REST ROD,UPPER	(1)
4		119-69409	THREAD GUIDE ARM B	(2)
5		B3395-704-000-A	SPOOL REST ROD JOINT	(1)
6		B3318-704-L00-A	THREAD GUIDE ARM JOINT	(2)
7		B3311-704-000	SPOOL REST ROD RUBBER CAP	(1)
8		B3320-704-L00-A	SPOOL PIN	(2)
9		119-66504	SPOOL REST	(2)
10		B3311-012-000	SPOOL REST CUSHION	(2)
11		111-85501	SPOOL RETAINER	(2)
12		B3317-704-000	NUT C15	(1)
13		B3319-704-L00	THREAD GUIDE	(2)
14		WP-1612616-SE	WASHER 16X30X2.6	(2)
15		SH-4051405-SE	SCREW M5X0.8 L=14	(2)
16		NM-6050001-SE	NUT M5X0.8	(2)
17		SM-6061610-SC	SCREW M6 L=16	(2)
18		NM-6050001-SE	NUT M5X0.8	(2)
19		MAO-11532000	CORD STAPLE	(3)

17. BELT COVER COMPONENTS

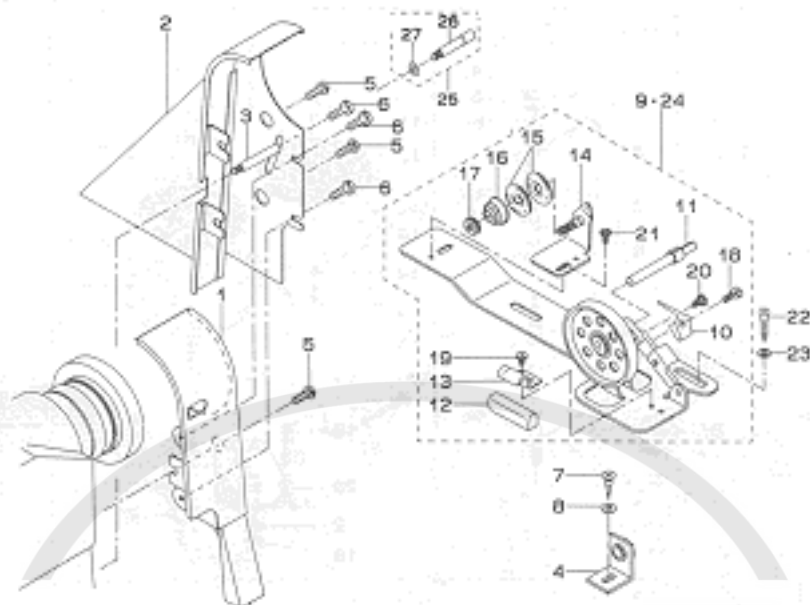

REF.NO	NOTE	PART NO.	DESCRIPTION	Qty
1		225-35009	BELT COVER A	1
2		225-35108	BELT COVER B	1
3		100-39105	BELT COVER SUPPORT STUD	1
4		100-39659	BELT COVER PRESS PLATE	1
5		SS-4150915-SP	SCREW 15/64-28 L=9	3
6		SS-6110480-SP	SCREW 11/64-40 L=4.3	3
7		SK-3482500-SC	WOOD SCREW D=4.8 L=25	1
8		WP-0501016-SC	WASHER 5X10.5X1	1
9		225-37054	BOBBIN DEVICE ASM.	1
10		225-37203	BOBBIN PRESSER	(1)
11		83204-555-000	BOBBIN WINDER POST	(1)
12		83211-555-000	RUBBER BRAKE	(1)
13		83212-555-000	PRESSER PLATE	(1)
14		D3213-555-DA0	THREAD TENSION BRACKET ASM.	(1)
15		83126-012-000	THREAD TENSION DISK	(2)
16		83129-012-800	THREAD TENSION SPRING	(1)
17		83125-012-000	THREAD TENSION NUT	(1)
18		SS-7081310-SP	SCREW 1/8-44 L=12.5	(1)
19		SS-7110350-SP	SCREW 11/64-40 L=3	(1)
20		SD-0480261-SP	HINGE SCREW D=4.0 H=2.6	(1)
21		SS-4110515-SP	SCREW 11/64-40 L=5	(1)
22		SK-3482500-SC	WOOD SCREW D=4.8 L=25	2
23		WP-0501016-SC	WASHER 5X10.5X1	2
24	#01	225-37153	BOBBIN DEVICE ASM.	1
25	#02	225-35402	SYNCHRONIZER SUPPORT ASM.	1
26		225-35454	SYNCHRONIZER SUPPORT ASM.	(1)
27		WP-0450801-SD	WASHER 4.5X10.0X0.8	(1)

Note (注記) #01...VARIOUS NOS.FOR DESTINATIONS
 #02...SPECIAL ORDER PART

18. OIL RESERVOIR & KNEE LIFTER COMPONENTS

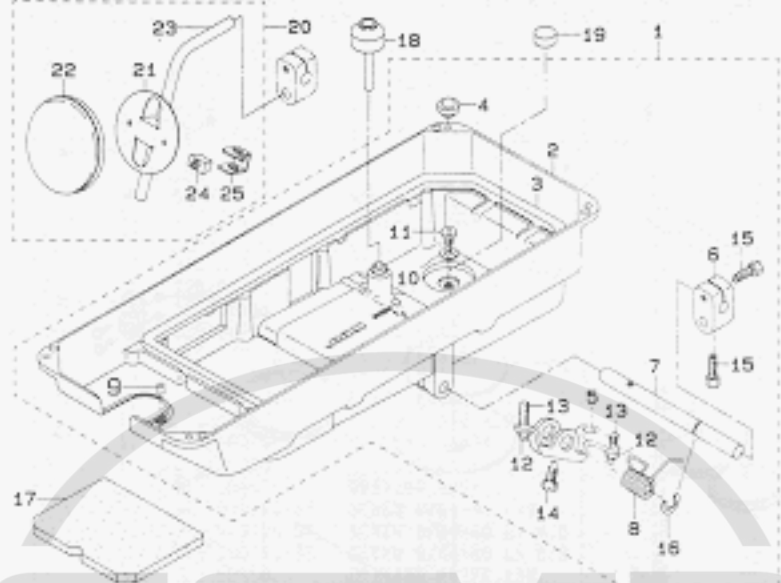

REF.NO	NOTE	PART NO.	DESCRIPTION	Qty
1		225-34051	OIL RESERVOIR ASM.	1
2		225-34002	OIL RESERVOIR	(1)
3		100-38107	OIL RESERVOIR GASKET	(1)
4		110-47107	RUBBER CUSHION	(4)
5		110-24007	CONNECTING ROD, VERTICAL	(1)
6		110-24502	KNEE PRESS LOD BEARING BRACKET	(1)
7		110-24205	KNEE PRESS ROD	(1)
8		110-24106	SPRING	(1)
9		81115-850-000	RUBBER PLUG	(1)
10		80-0982401-00	RUBBER RING	(1)
11		SS-6700710-SH	SCREW	(1)
12		NS-6150430-SR	NUT 15/64-28	(2)
13		SS-8153010-SR	SCREW 15/64-28 L=30	(2)
14		SS-9151810-SR	SCREW	(1)
15		SS-9182010-SH	SCREW 9/32-20 L=20	(2)
16		RE-1000000-K0	E-RING	(1)
17		225-34101	OIL RESERVOIR BASE	1
18		83421-555-000	KNEE PRESS LIFTER ROD	1
19		88228-125-000	OIL RESERVOIR MAGNET	1
20		110-23751	KNEE PRESS PLATE ASM.	1
21		110-23702	KNEE PRESS PLATE	(1)
22		83431-552-000-A	KNEE PRESS PLATE COVER	(1)
23		83419-122-000	KNEE LIFTER PLATE ROD	(1)
24		110-24403	RUBBER	(1)
25		110-23801	KNEE PRESS PLATE HOLDER	(1)

19. EXCLUSIVE PARTS FOR LZ-2286

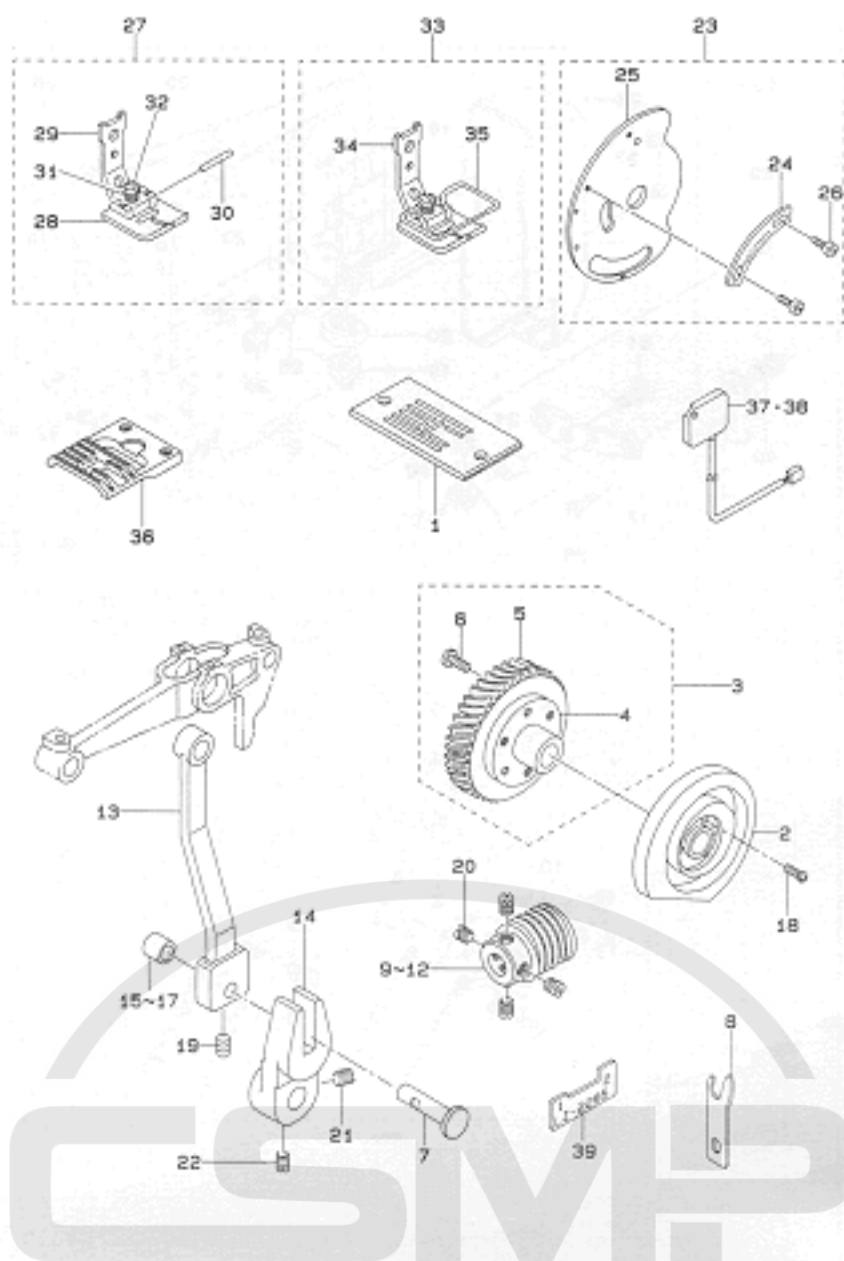

REF.NO	NOTE	PART NO.	DESCRIPTION	Qty
1		225-80005	THROAT PLATE	1
2		225-85509	NEEDLE VIBRATING CAM	1
3		225-85657	WORM WHEEL COMPL.	1
4		225-85608	WORM WHEEL HUB	(1)
5		100-43412	WORM WHEEL	(1)
6		SS-7111120-SP	SCREW 11/64-40 L=10.5	(3)
7		225-85707	SHAFT	1
8		225-88507	STOPPER	1
9	#01	100-43016	WORM	1
10	#01	100-43115	WORM	1
11	#01	100-43214	WORM	1
12	#01	100-43313	WORM	1
13		100-44014	NEEDLE VIBRATING ROD	1
14		100-44105	ROD GUIDE	1
15	#01	B2502-280-BOA	FEED CAM ROLLER	1
16	#01	B2502-280-BOB	FEED CAM ROLLER	1
17	#01	B2502-280-BOC	FEED CAM ROLLER	1
18		SS-7111410-SP	SCREW 11/64-40 L=14	3
19		SS-8110422-TP	SCREW 11/64-40 L=4	1
20		SS-8680610-TP	SCREW 1/4-40 L=6	4
21		SS-8680810-TP	SCREW 1/4-40 L=8	1
22		SS-8680970-TP	SCREW 1/4-40 L= 8.5	1
23		225-86259	SCALE ASM.	1
24		225-86200	SCALE	(1)
25		225-12453	SCALE MOUNTING BASE COMPL.	(1)
26		SS-8080320-SP	SCREW 1/8-44 L= 2.5	(2)
27		225-80252	PRESSER FOOT ASM.	1
28		225-80203	PRESSER FOOT (LOWER)	1
29		225-45206	PRESSER FOOT (UPPER)	1
30		100-21103	PRESSER PIN	1
31		B1525-582-000	SPRING	1
32		SS-8090810-SP	SCREW 9/64-40 L= 7.5	1
33		225-80260	PRESSER FOOT ASM.	1
34		225-80252	PRESSER FOOT ASM.	1
35		225-45404	SAFETY COVER	1
36		225-80104	FEEDER	1
37	#02	M6094-350-AAL	RESISTANCE PACK AL ASM.	1
38	#03	M6094-350-AAP	RESISTANCE PACK AF ASM.	1
39		225-86705	TIMING GAUGE	1

Note (注記) #01...SELECTIVE PART
 #02...FOR LZ-2286-7
 #03...VARIOUS NOS.FOR DESTINATIONS

*ALL PARTS OTHER THAN ABOVE ARE SAME AS THOSE OF LZ-2280.

20. EXCLUSIVE PARTS FOR LZ-2285(1)

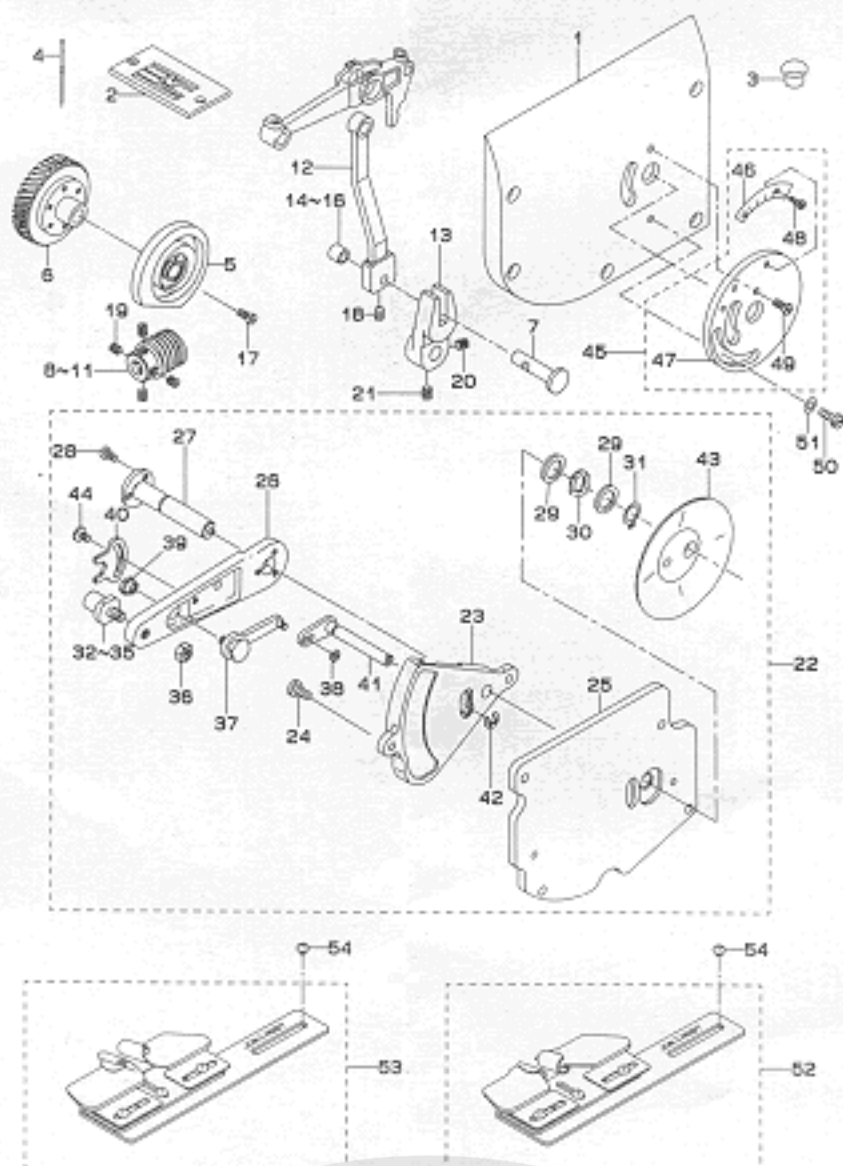

REF. NO	NOTE	PART NO.	DESCRIPTION	Qty
1		225-92505	ARM SIDE COVER	1
2		100-61554	THROAT PLATE ASH.	1
3		TA-1871602-RO	RUBBER PLUG	1
4		WC-1923F08-00	NEEDLE 438SUX 80	1
5		225-85509	NEEDLE VIBRATING CAM	1
6		225-85657	WORM WHEEL COMPL.	1
7		225-85707	SHAFT	1
8	#01	100-43016	WORM	1
9	#01	100-43115	WORM	1
10	#01	100-43214	WORM	1
11	#01	100-43313	WORM	1
12		100-44014	NEEDLE VIBRATING ROD	1
13		100-44105	ROD GUIDE	1
14	#01	B2502-280-B0A	FEED CAM ROLLER	1
15	#01	B2502-280-B0B	FEED CAM ROLLER	1
16	#01	B2502-280-B0C	FEED CAM ROLLER	1
17		SS-7111410-SP	SCREW 11/64-40 L=14	3
18		SS-8110422-TP	SCREW 11/64-40 L=4	1
19		SS-8660610-TP	SCREW 1/4-40 L=6	4
20		SS-8680810-TP	SCREW 1/4-40 L=8	1
21		SS-8660970-TP	SCREW 1/4-40 L= 8.5	1
22		225-92853	BASE ASH.	1
23		100-54112	ARM SETTING BASE	(1)
24		SS-7110910-TP	SCREW 11/64-40 L= 8.5	(2)
25		225-92804	MOUNTING PLATE	(1)
26		100-16012	ARM	(1)
27		225-12701	SHAFT	(1)
28		SS-6090620-SP	SCREW 9/64-40 L=6	(3)
29		WP-1020616-SD	WASHER	(2)
30		WZ-1052010-KP	WAVED WASHER	(1)
31		RC-0100001-KP	SNAP RING M10	(1)
32	#01	100-16210	SHAFT	(1)
33	#01	100-16319	SHAFT	(1)
34	#01	100-16418	SHAFT	(1)
35	#01	100-16517	SHAFT	(1)
36		NS-6150310-SP	NUT 15/64-28	(1)
37		100-17168	STOPPER ASH.	(1)
38		RE-0200000-K0	E-RING	(1)
39		100-18000	NUT	(1)
40		100-18109	NUT STOPPER	(1)
41		100-15300	LEVER ASH.	(1)
42		RE-0400000-K0	E-SHAPED SNAP RING (4MM)	(1)
43		100-17606	OIL SHIELD	(1)
44		SS-6090520-SP	SCREW 9/64-40 L= 5.0	(1)
45		225-90053	SCALE ASH.	1
46		225-86200	SCALE	(1)
47		225-92802	SCALE MOUNTING BASE	(1)
48		SS-8080320-SP	SCREW 1/8-44 L= 2.5	(2)
49		SS-6111010-SP	SCREW 11/64-40 L= 9.5	(1)
50		SS-6110510-SP	SCREW 11/64-40 L=5	1
51		WP-0480850-SP	WASHER 4.8X8.4X0.8	1
52	#02	MAN-097000A0	FAGOTING FELLER	1
53		MAN-097008A0	FAGOTING FOLDER ASH.	1
54		SS-5110710-SP	SCREW 11/64-40 L=7	2

Note (注記) #01...SELECTIVE PART
#02...SPECIAL ORDER PART

*ALL PARTS OTHER THAN ABOVE ARE SAME AS THOSE OF LZ-2280.

21. EXCLUSIVE PARTS FOR LZ-2285(2)

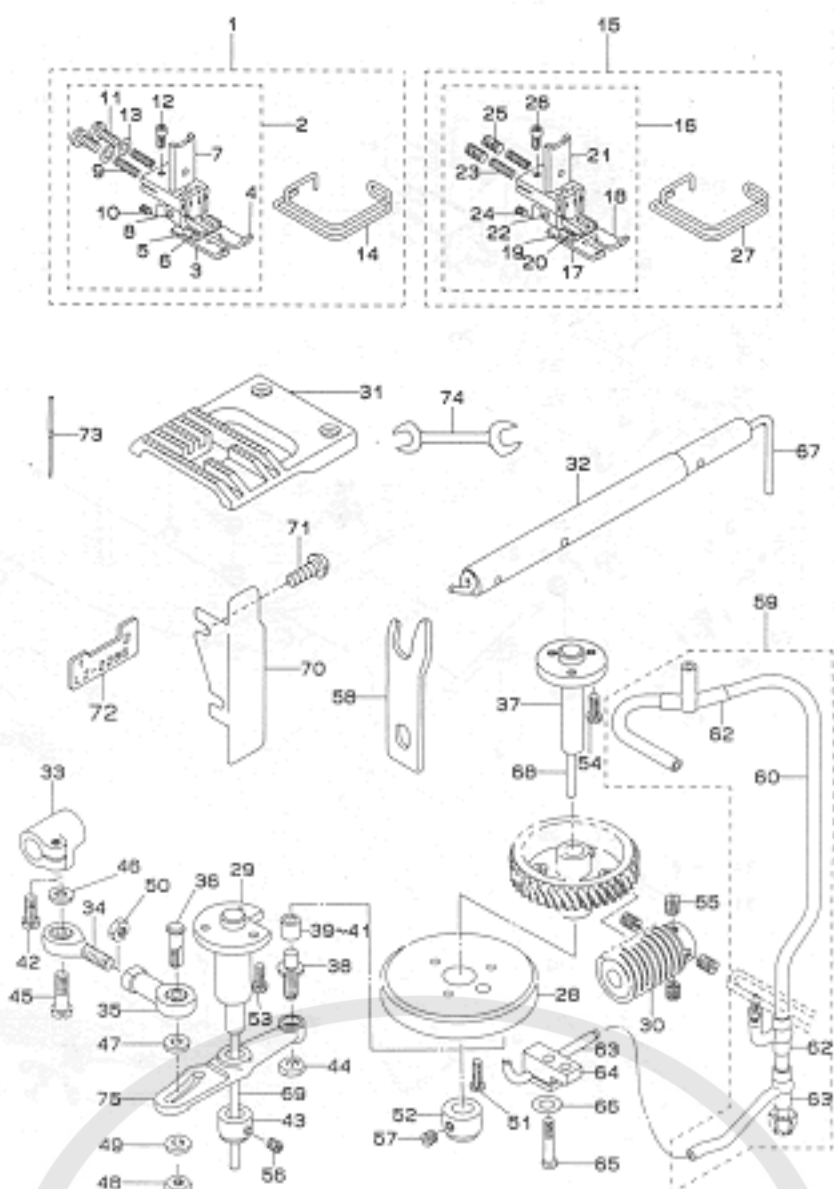

REF. NO	NOTE	PART NO.	DESCRIPTION	Qty
1	#01	225-91504	PRESSER FOOT ASM.	1
2		225-91559	PRESSER FOOT ASM.	(1)
3		100-82701	PRESSER FOOT, LEFT	(1)
4		100-82800	PRESSER FOOT, RIGHT	(1)
5		225-21408	PRESSER FOOT ARM	(2)
6		100-83303	PIN	(2)
7		100-83402	PRESSER FOOT, UPPER	(1)
8		100-83501	PIN	(1)
9		100-83600	SPRING	(2)
10		SS-8080410-TP	SCREW 1/8-44 L=3.5	(1)
11		SS-7111110-TP	SCREW 11/64-40 L=10.5	(2)
12		SS-6580752-TP	SCREW 1/8-40 L=7	(1)
13		WF-0220300-SC	WASHER	(2)
14		225-91101	FINGER GUARD	(1)
15	#02	225-91693	PRESSER FOOT ASM.	1
16		225-91655	PRESSER FOOT ASM.	(1)
17		100-82701	PRESSER FOOT, LEFT	(1)
18		100-82800	PRESSER FOOT, RIGHT	(1)
19		100-83204	PRESSER FOOT ARM	(2)
20		100-83303	PIN	(2)
21		100-83402	PRESSER FOOT, UPPER	(1)
22		100-83501	PIN	(1)
23		100-83600	SPRING	(2)
24		SS-8080410-TP	SCREW 1/8-44 L=3.5	(1)
25		SS-8111210-TP	SCREW 11/64-40 L=9.5	(2)
26		SS-6580752-TP	SCREW 1/8-40 L=7	(1)
27		225-91101	FINGER GUARD	(1)
28		225-90400	FEED CAM	1
29		225-90500	SHAFT	1
30		100-63008	WORM	1
31		100-64004	FEED DOG	1
32		100-64103	FEED ROCKER SHAFT	1
33		100-64202	FEED ROCKER SHAFT CRANK	1
34		100-64301	BALL JOINT A	1
35		100-64400	BALL JOINT B	1
36		100-64508	FEED REGULATOR	1
37		100-64905	FEED CAM SHAFT	1
38		100-65001	FEED CAM ROLLER SHAFT	1
39	#03	B2502-280-90A	FEED CAM ROLLER	1
40	#03	B2502-280-90B	FEED CAM ROLLER	1
41		B2502-280-90C	FEED CAM ROLLER	1
42		SS-8121210-SP	SCREW 3/16-28 L=12	1
43		CS-1031210-SH	THRUST COLLAR ASM. D=10.32 W=1	1
44		NS-6150430-SP	NUT 15/64-28	1
45		SD-0921051-SP	HIGH SCREW D=6 H=13	1
46		WF-0612008-SP	WASHER 6.1X11X2	1
47		WF-0612008-SP	WASHER 6.1X11X2	1
48		NS-6150430-SP	NUT 15/64-28	1
49		WF-0521018-SH	WASHER	1
50		NS-6280001-SE	NUT M8	1
51		SS-7111410-SP	SCREW 11/64-40 L=14	3
52		CS-1031210-SH	THRUST COLLAR ASM. D=10.32 W=1	1
53		SS-9861120-CP	SCREW 1/4-40 L=10.5	2
54		SS-9861120-CP	SCREW 1/4-40 L=10.5	2
55		SS-8860910-TP	SCREW 1/4-40 L=6	4
56		SS-8860910-TP	SCREW 1/4-40 L=6	2
57		SS-8860910-TP	SCREW 1/4-40 L=6	2
58		225-88507	STOPPER	1
59		225-90855	OIL SUPPLY PIPE ASM.	1
60		225-90800	OIL SUPPLY PIPE	(1)
61		100-35500	RUBBER JOINT	(1)
62		B3527-552-030	RUBBER JOINT	(2)
63		100-65200	CAM OIL PIPE	(1)
64		B3554-481-000	HOLDER	1
65		SS-4118915-SP	SCREW 11/64-40 L=8	1
66		WF-0591010-S0	WASHER 5X10.5X1	1
67		OQ-5096000-00	OIL WICK	0.3
68		OQ-5096000-00	OIL WICK	0.1
69		OQ-3030000-00	OIL WICK	0.1
70		225-93107	BELT COVER	1
71		SS-4120015-SP	SCREW 3/16-28 L=8	2
72		225-88705	TIMING GAUGE	1
73		NC-1923P08-05	NEEDLE (43850K 80-5)	1
74		B9113-012-000	WRENCH (8X10)	1
75		225-90301	LEVER	1

Note (注記) #01...NO NECESSARY PART ACCORDING TO DESTINATIONS
 #02...SPECIAL ORDER PART
 #03...SELECTIVE PART

*ALL PARTS OTHER THAN ABOVE ARE SAME AS THOSE OF LZ-2280.

22. EXCLUSIVE PARTS FOR LZ2287

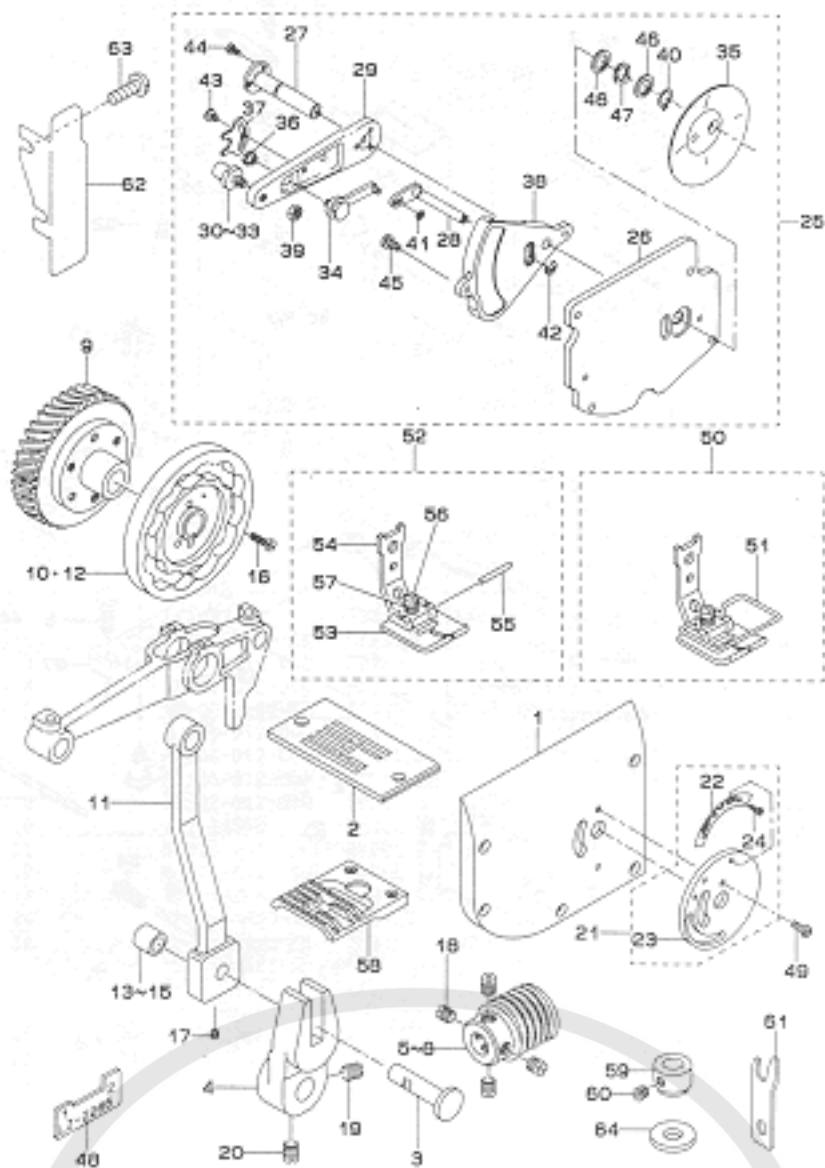

REF. NO	NOTE	PART NO.	DESCRIPTION	Qty
1		225-92505	ARM SIDE COVER	1
2		225-80505	THROAT PLATE	1
3		225-85707	SHAFT	1
4		100-44105	ROD GUIDE	1
5	#01	100-53207	WORM ASK. A	1
6	#01	100-53106	WORM B	1
7	#01	100-53205	WORM	1
8	#01	100-53304	WORM	1
9		100-53452	WORM WHEEL ASK.	1
10	#02	100-53502	NEEDLE VIBRATING CAM A	1
11		100-54005	NEEDLE VIBRATING ROD	1
12	#03	100-53901	NEEDLE VIBRATING CAM B	1
13	#01	82502-280-80A	FEED CAM ROLLER	1
14	#01	82502-280-80B	FEED CAM ROLLER	1
15	#01	82502-280-80C	FEED CAM ROLLER	1
16		SS-7113410-SP	SCREW 11/84-40 L=14	3
17		SS-8110422-TP	SCREW 11/84-40 L=4	1
18		SS-8680610-TP	SCREW 1/4-40 L=6	4
19		SS-8680810-TP	SCREW 1/4-40 L=8	1
20		SS-8680970-TP	SCREW 1/4-40 L= 8.5	1
21		225-92752	SCALE ASK.	1
22		225-92703	SCALE	(1)
23		225-92802	SCALE MOUNTING BASE	(1)
24		SS-8080320-SP	SCREW 1/8-44 L= 2.5	(2)
25		225-92853	BASE ASK.	1
26		225-92804	MOUNTING PLATE	(1)
27		225-12701	SHAFT	(1)
28		100-15300	LEVER ASK.	(1)
29		100-16012	ARM	(1)
30	#01	100-16210	SHAFT	(1)
31	#01	100-16310	SHAFT	(1)
32	#01	100-16418	SHAFT	(1)
33	#01	100-16517	SHAFT	(1)
34		100-17108	STOPPER ASK.	(1)
35		100-17800	OIL SHIELD	(1)
36		100-18000	NUT	(1)
37		100-18109	NUT STOPPER	(1)
38		100-54112	ARM SETTING BASE	(1)
39		NS-8150310-SP	NUT 15/64-28	(1)
40		RC-0100301-KP	SNAP RING M10	1
41		RE-0200000-K0	E-RING	1
42		RE-0400000-K0	E-SHAPED SNAP RING (4MM)	1
43		SS-8090520-SP	SCREW 9/64-40 L= 5.0	1
44		SS-8090620-SP	SCREW 9/64-40 L=6	3
45		SS-7110210-TP	SCREW 11/84-40 L= 8.5	2
46		WP-1020516-SD	WASHER	2
47		W2-1052010-KP	WAVED WASHER	1
48		225-80705	TIMING GAUGE	1
49		SS-6111010-SP	SCREW 11/84-40 L= 9.5	1
50		225-80250	PRESSER FOOT ASK.	1
51		225-45404	SAFETY COVER	(1)
52		225-80252	PRESSER FOOT ASK.	(1)
53		225-80203	PRESSER FOOT (LOWER)	(1)
54		225-45208	PRESSER FOOT (UPPER)	(1)
55		100-21103	PRESSER PIN	(1)
56		81525-582-000	SPRING	(1)
57		SS-8090810-SP	SCREW 9/64-40 L= 7.5	(1)
58		225-80104	FEEDER	1
59		CS-1031210-SH	THRUST COLLAR ASK. D=10.32 W=1	1
60		SS-8680610-TP	SCREW 1/4-40 L=6	2
61		225-80507	STOPPER	1
62		225-93107	BELT COVER	1
63		SS-4120615-SP	SCREW 3/16-28 L=6	2
64		115-27207	WASHER	1

Note (注記) #01... SELECTIVE PART
 #02... FOR LZ-2287
 #03... FOR LZ-2287B

*ALL PARTS OTHER THAN ABOVE ARE SAME AS THOSE OF LZ-2280.